

>>Schubkasten/0391<<

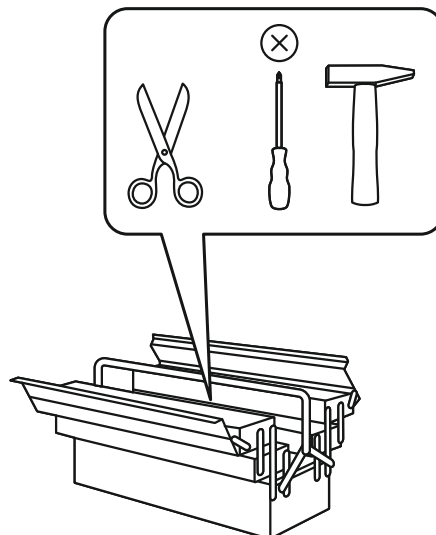

Aus Sicherheitsgründen ist die Nutzung des Schubkastens nur im Babybett möglich.

- | | | | |
|--|----------------------------------|-----------------------------------|---------------------------------------|
|  | D Montageanleitung | GB Assembly instructions | FR Notice de montage |
| | TR Montaj talimatı | IT Istruzioni di montaggio | NL Handleiding voor de montage |
| | RU Инструкция по монтажу | CZ Montážní návod | HU Szerelési útmutató |
| | RO Instrucțiuni de montaj | PL Instrukcja montażu | SK Návod na montáž |

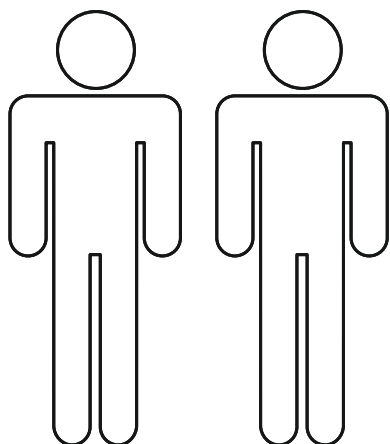

Service • Assistenza • Dienstverlening • Serwis Servis • Szerviz • Сервисная служба

Name • Nom • Nome • Naam • Nazwa • Jméno •
Názov • Név • Denumire • Isim • Название

Schubkasten/0391

Nr. • No. • N° • Номер • Č • Sz

0391/SKV

Typ • Type • Тип • Típus • Тіро • Тип

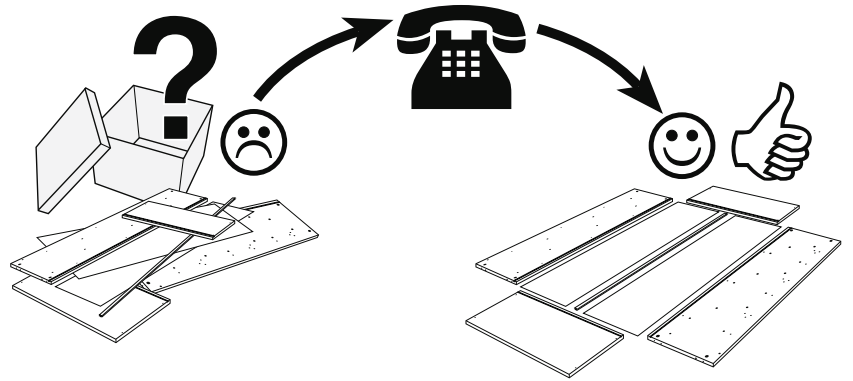
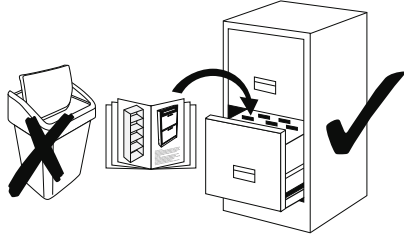

1-199		1-330		2-10		2-20	
8x	6,3x9,5	4x	M4x10	8x		8x	
3-130		5-130					
2x		1x					

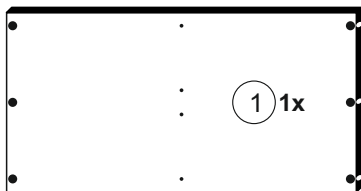

1388 x 712

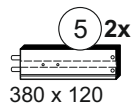

380 x 120

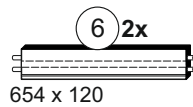

654 x 120

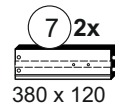

380 x 120



1388 x 120



208 x 330

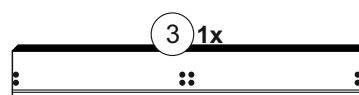

1384 x 184

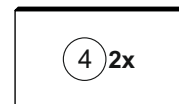

664 x 380

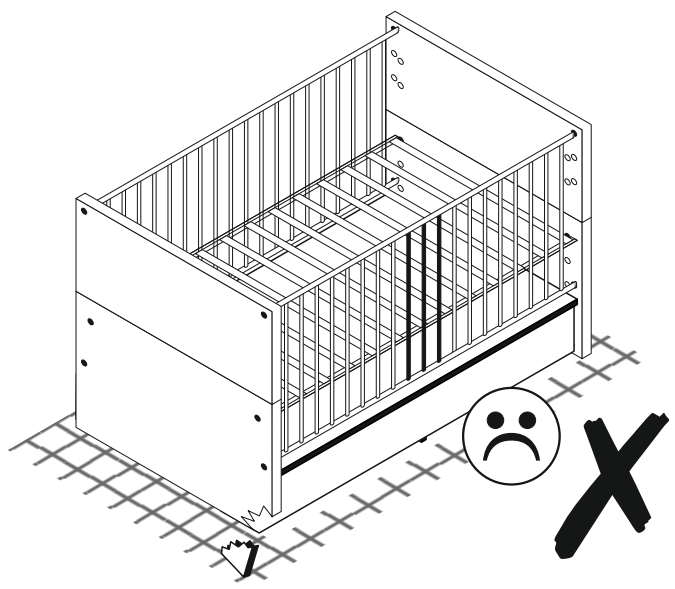

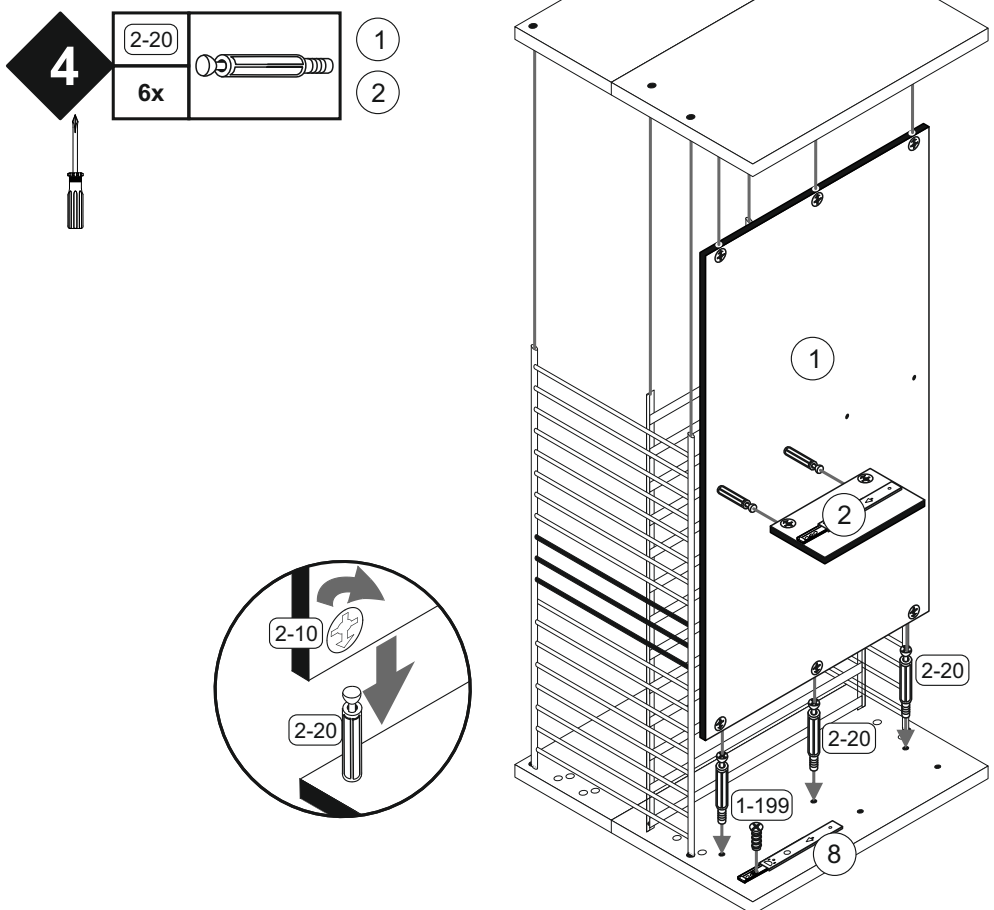
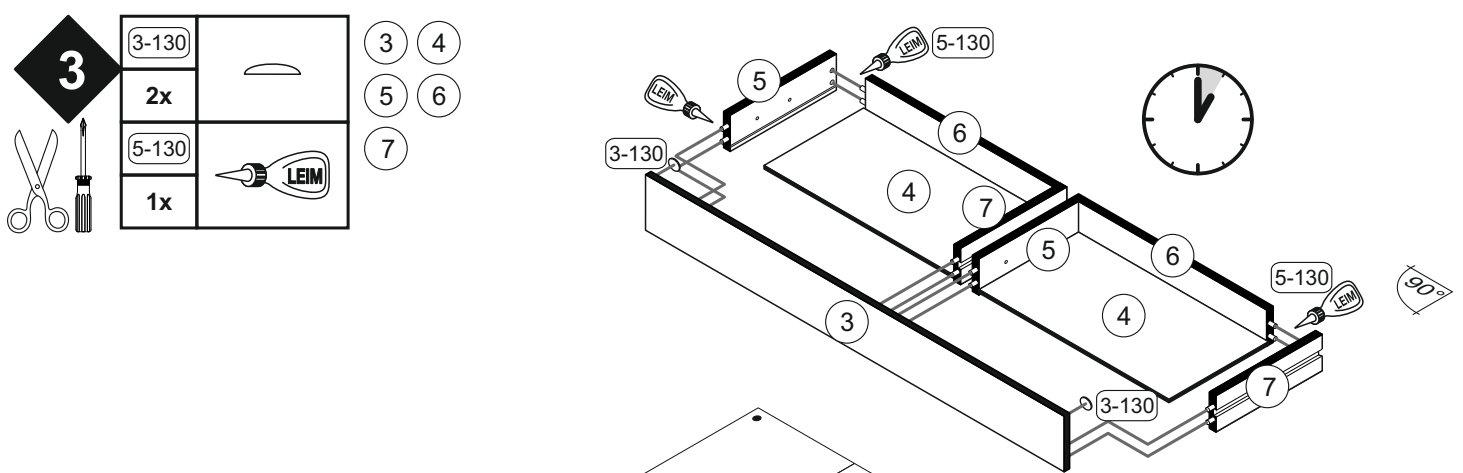
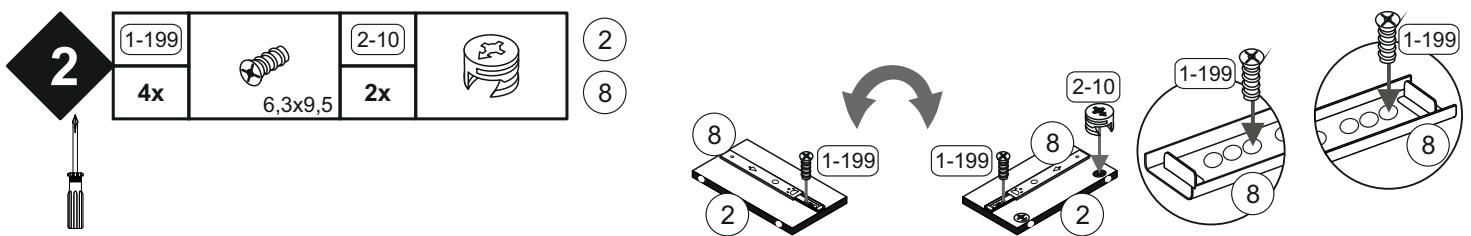
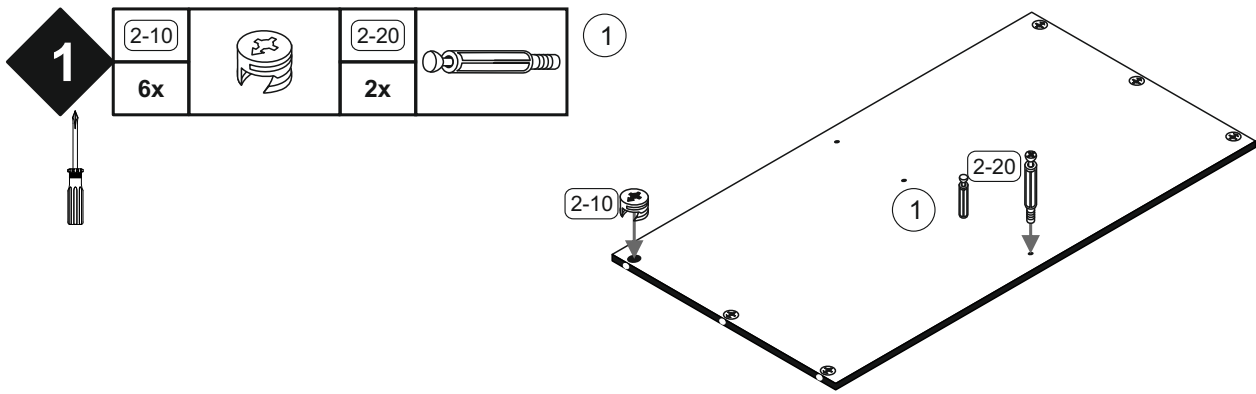

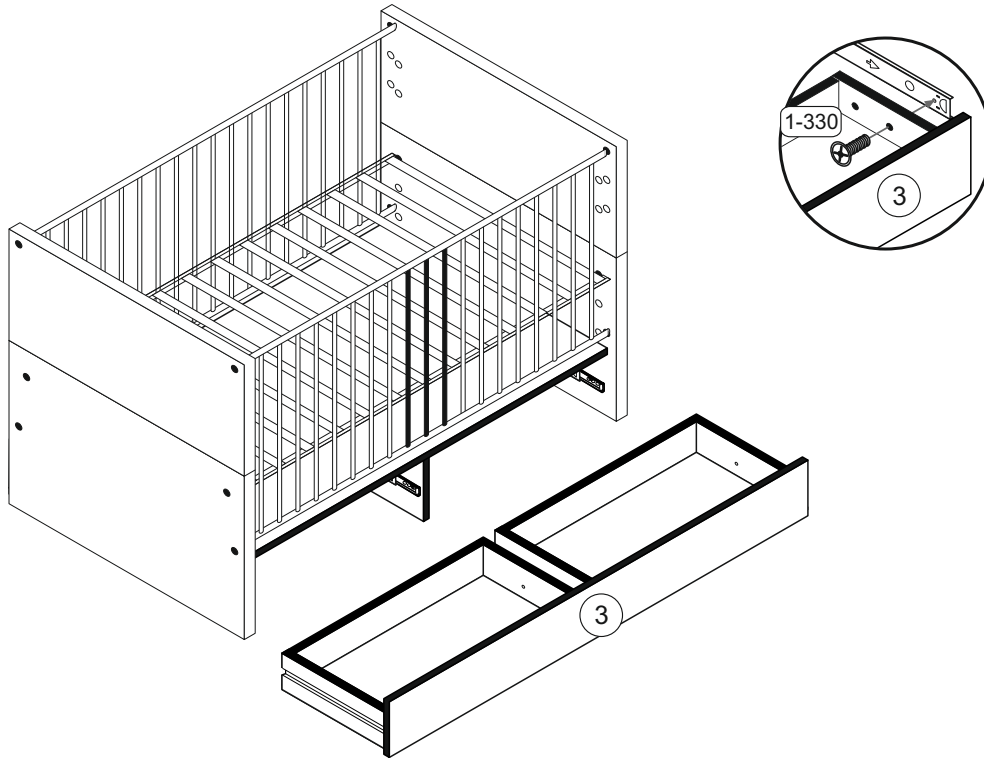
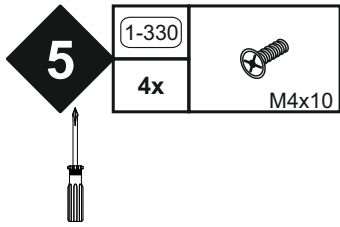

Aus Sicherheitsgründen ist die Nutzung des Schubkastens nur im Babybett möglich.

>> Seitenteile <<

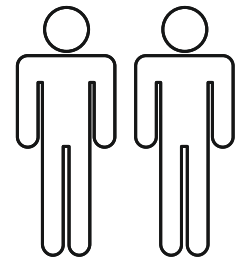
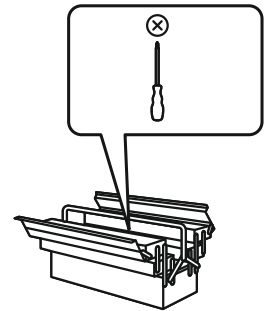
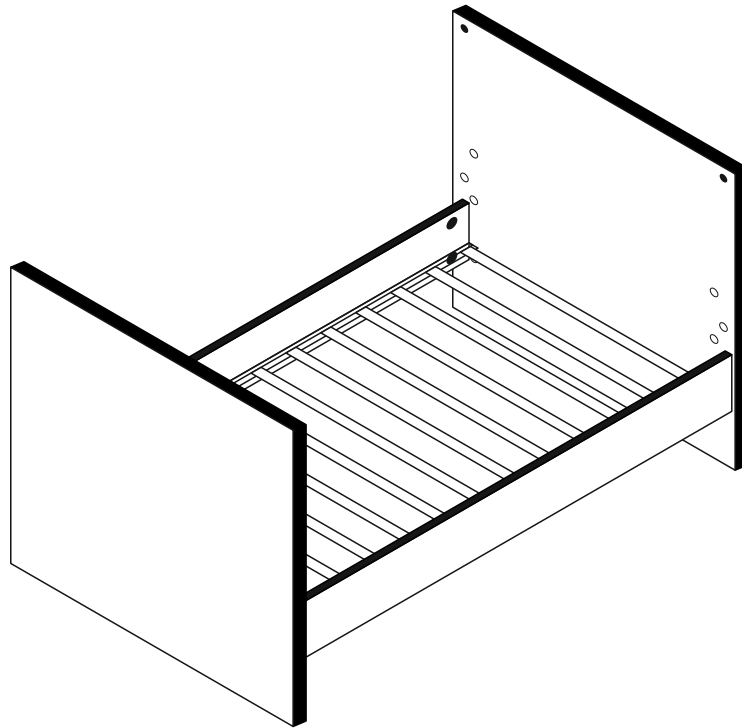

- (D) Montageanleitung (GB) Assembly instructions (FR) Notice de montage
(TR) Montaj talimatı (IT) Istruzioni di montaggio (NL) Handleiding voor de montage
(RU) Инструкция по монтажу (CZ) Montážní návod (HU) Szerelési útmutató
(RO) Instrucțiuni de montaj (PL) Instrukcja montażu (SK) Návod na montáž



Service • Assistenza • Dienstverlening • Serwis Servis • Szerviz • Сервисная служба

Name • Nom • Nome • Naam • Nazwa • Jméno •
Názov • Név • Denumire • Ísim • Название

Seitenteile

Nr. • No. • N° • Номер • Č • Sz

0414_ST

Typ • Type • Tip • Típus • Tipo • Тип

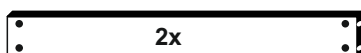
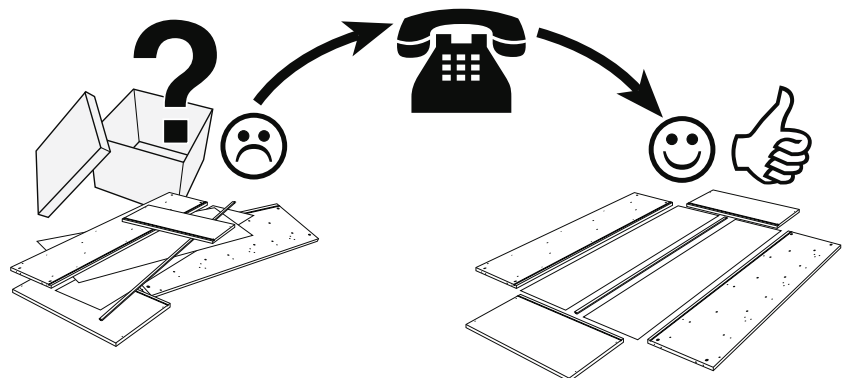
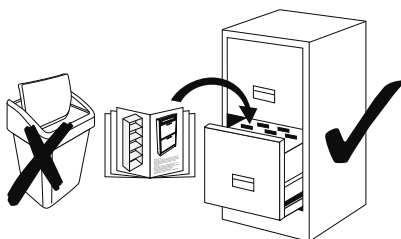

1388 x 156





Variante 1 : Steckverbindung

(Montage mit Bolzen )

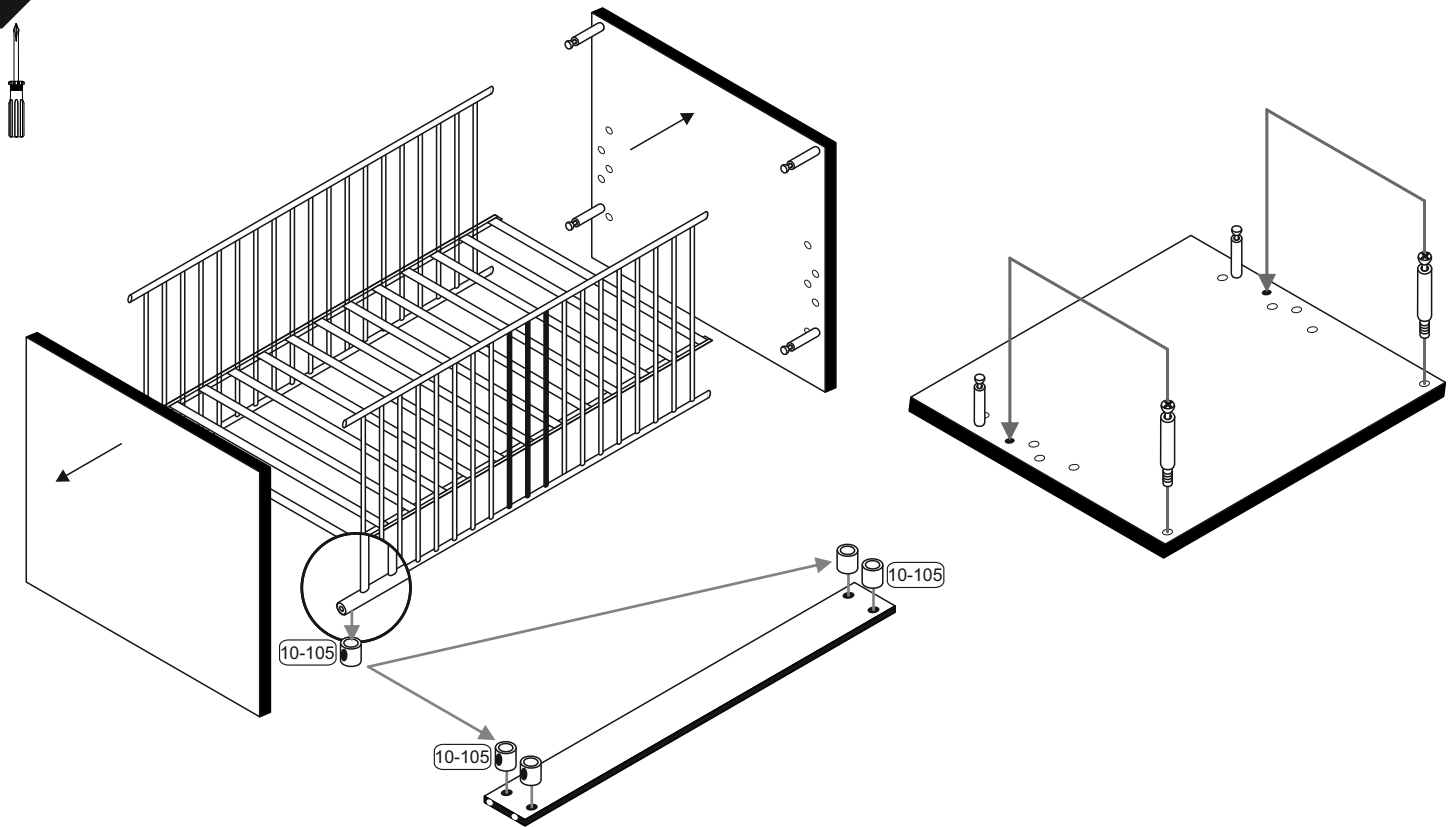
1

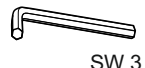

2

1-239		10-100	
1x	SW 3	8x	M6x8

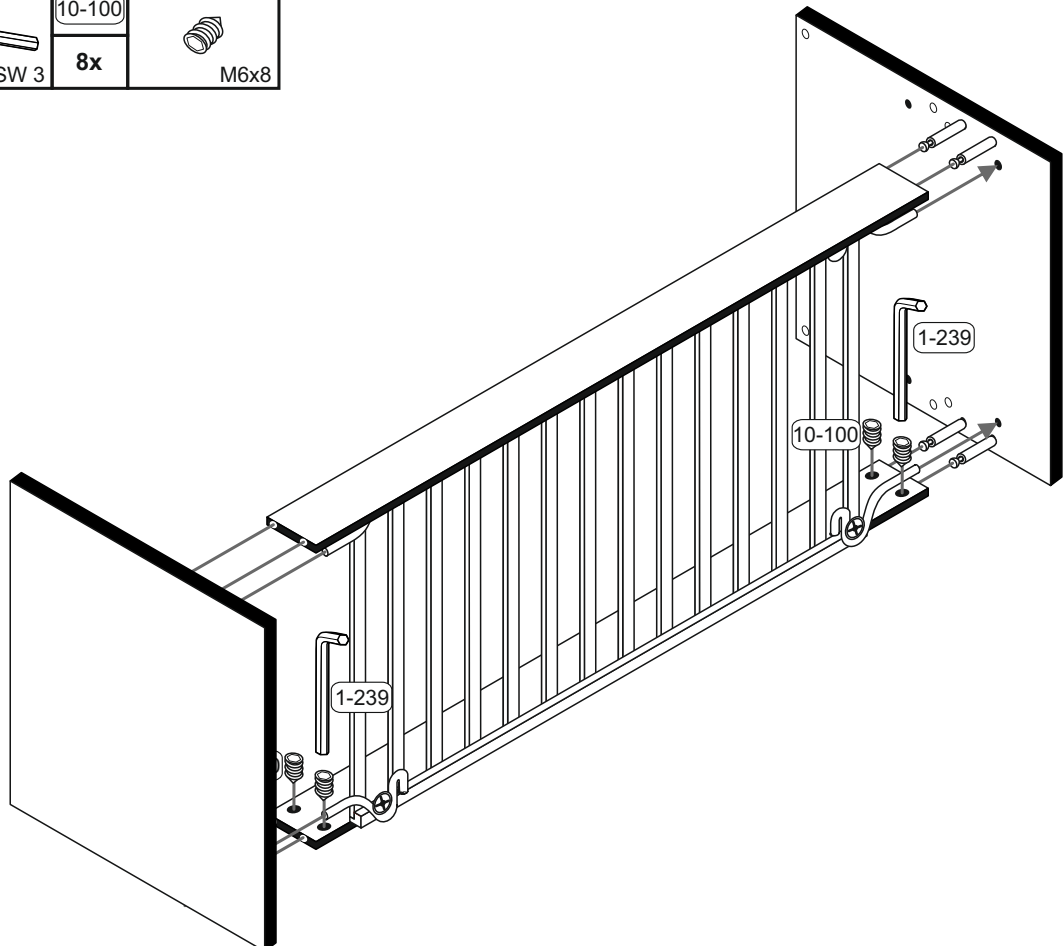

Variante 2 : Schraubverbindung

(Montage mit Schrauben )

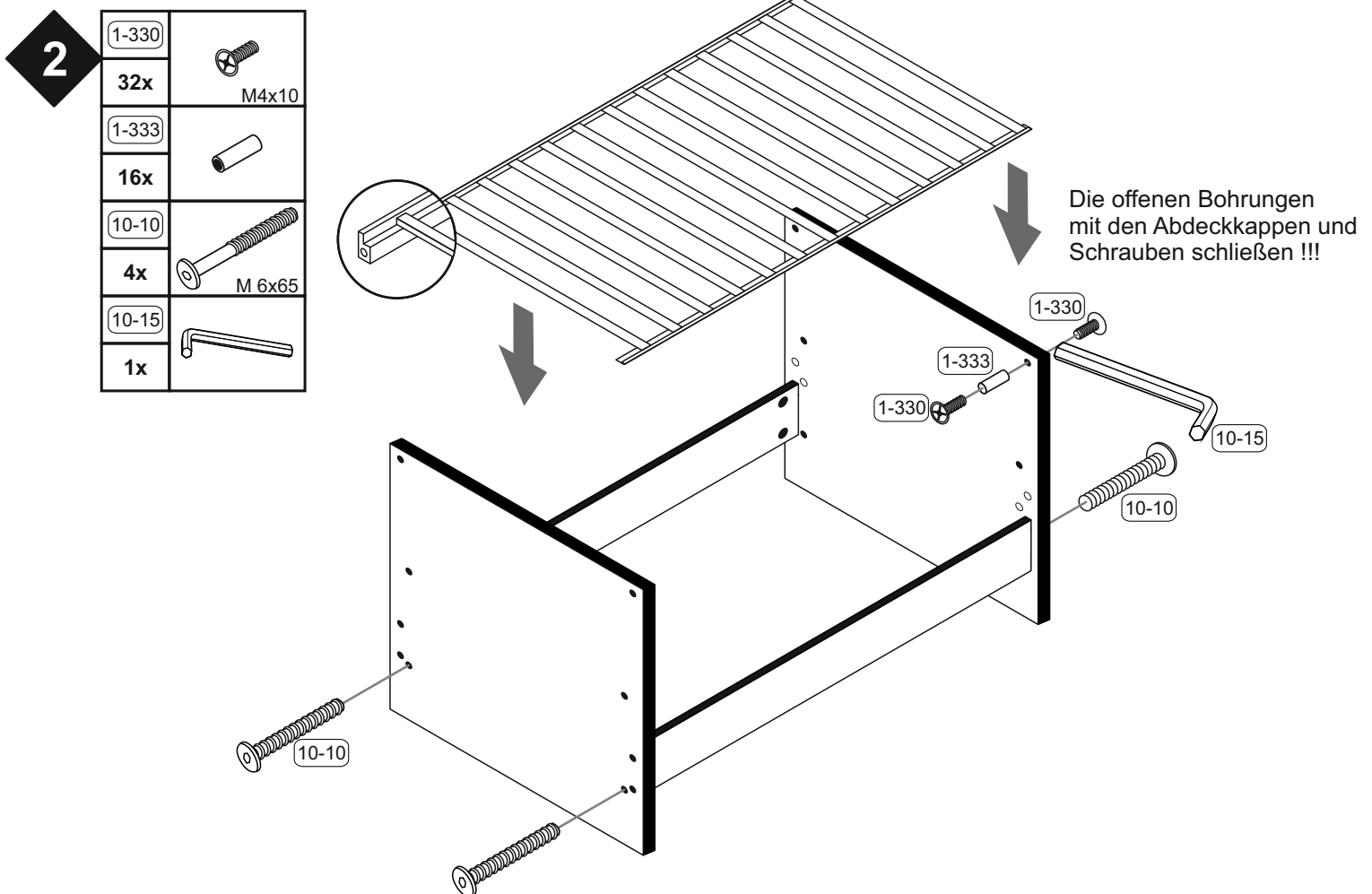
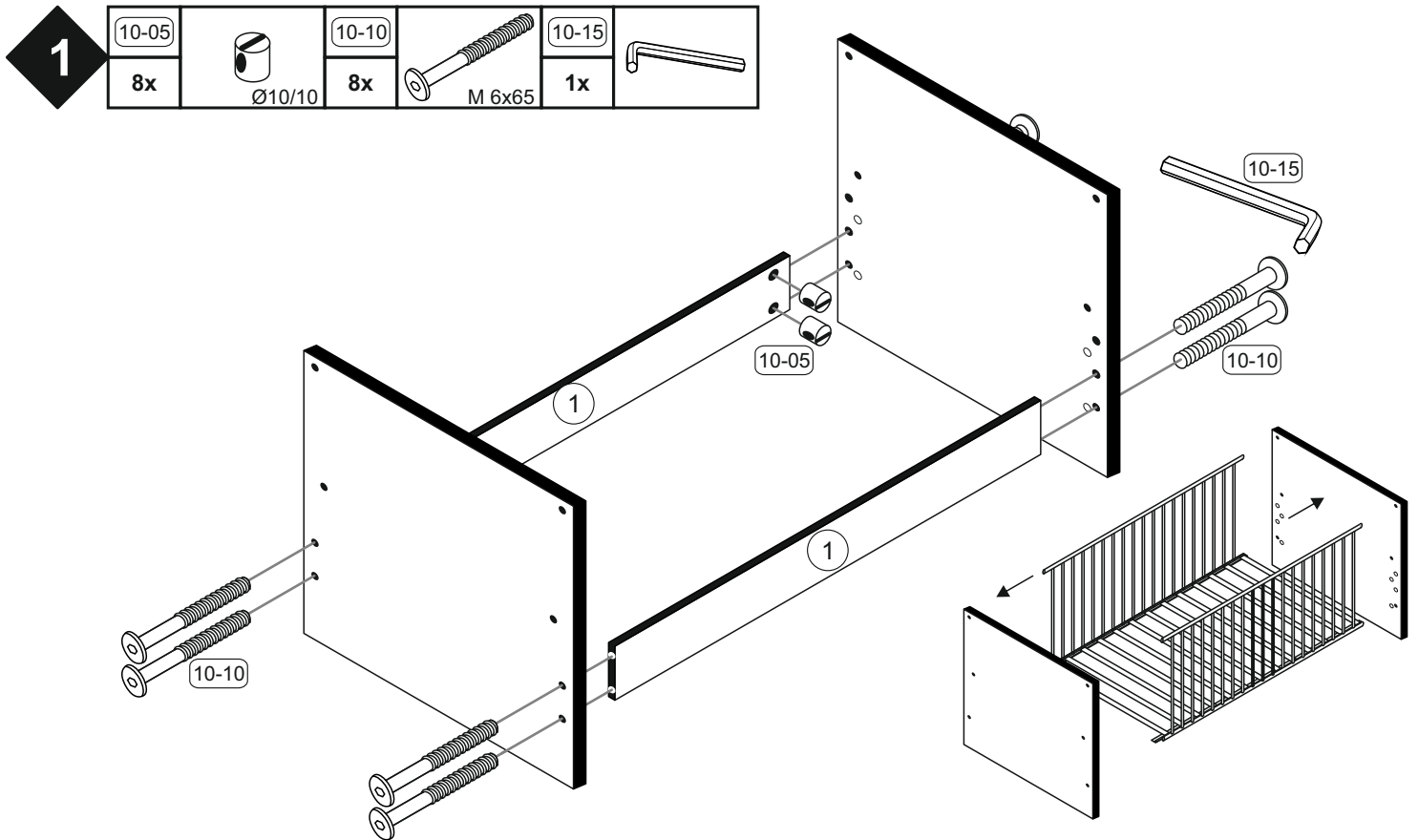



(D) Montageanleitung

(GB) Assembly instructions

(FR) Notice de montage

(TR) Montaj talimatı

(IT) Istruzioni di montaggio

(NL) Handleiding voor de montage

(RU) Инструкция по монтажу

(CZ) Montážní návod

(HU) Szerelési útmutató

(RO) Instrucțiuni de montaj

(PL) Instrukcja montażu

(SK) Návod na montáž

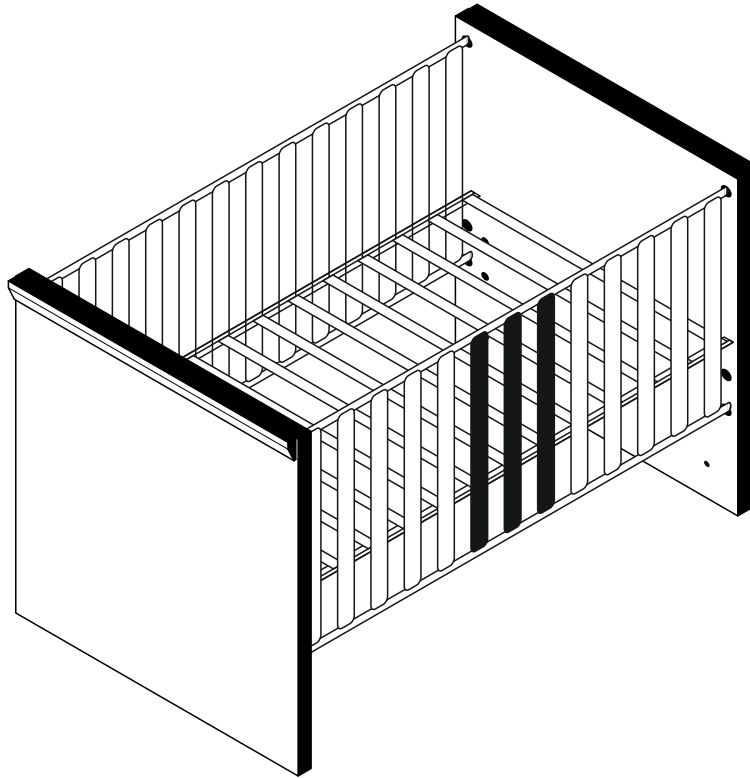









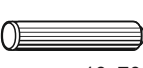

0442_BH-P1 Babybett

DIN EN 716-1

Service • Assistenza • Dienstverlening • Servis
Servis • Szerviz • Сервисная служба

	<p>Colli 1/2 : (1) (2) Beutel 1/1 Colli 2/2 : (3) (4) (5)</p>

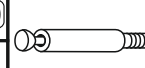
Beutel 1/1

1-239		2-109		5-130		10-80		10-85		10-90	
1x	SW 3	8x	10x70	2x	LEIM	2x	2x	2x	12x		
10-95		10-100		10-105		10-110		10-115			
4x		8x	M6x8	8x	M6x10	8x	12x		M 6		

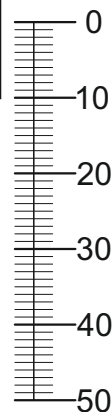

Colli 1/2

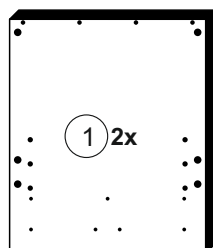

928 x 778

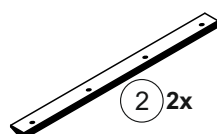

776 x 60

Colli 2/2

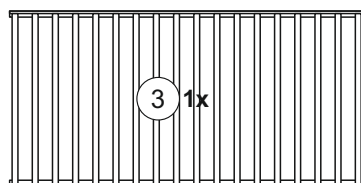

1388 x 680

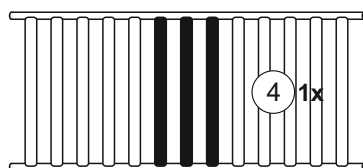

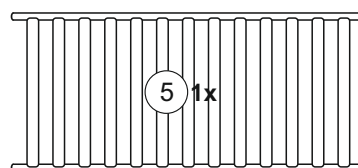

1388 x 630

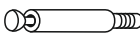

1388 x 630

- (D)** Defekte Teile dürfen nicht in das Kinderbett eingebaut werden. Wenden Sie sich an den Hersteller um ein Ersatzteil anzufordern.
- (GB)** Faulty parts may not be fitted into the cot. Contact the manufacturer to request a replacement part.
- (FR)** Des pièces défectueuses ne doivent pas être utilisées pour le montage du lit d'enfants. Contactez le fabricant pour commander des pièces de rechange.
- (TR)** Hasarlı parçalar çocuk karyolasına takılmamalıdır. Bir yedek parçasını talep etmek için üreticiye danışın.
- (IT)** Non montare sul letto per bambini eventuali parti difettate. Rivolgersi al produttore e chiedere una sostituzione.
- (NL)** Defecte onderdelen mogen niet in het kinderbed worden ingebouwd. Neem contact op met de fabrikant voor vervanging van het onderdeel.
- (RU)** Устанавливать дефектные части в детскую кровать запрещено. Обратитесь за заменой к производителю.
- (CZ)** Vadné části se nesmí montovat do dětské postýlky. Obraťte se na výrobce a vyžádejte si náhradní díl.
- (HU)** Hibás alkatrészeket nem szabad a gyermekágyba beszerelni. Forduljon ilyen esetben a gyártóhoz és kérje az alkatrész cseréjét.
- (RO)** Piesețe defecte nu pot fi sub nicio formă încorporate în patul copilului. Solicitați producătorului să vă expedieze piesa de schimb necesară.
- (PL)** Nigdy nie używaj uszkodzonych części do montażu łóżeczka. Skontaktuj się z producentem, by otrzymać części zamienne.
- (SK)** Do detskej postieľky sa nesmú namontovať poškodené diely. V prípade potreby náhradného dielu sa obráťte na svojho predajcu.

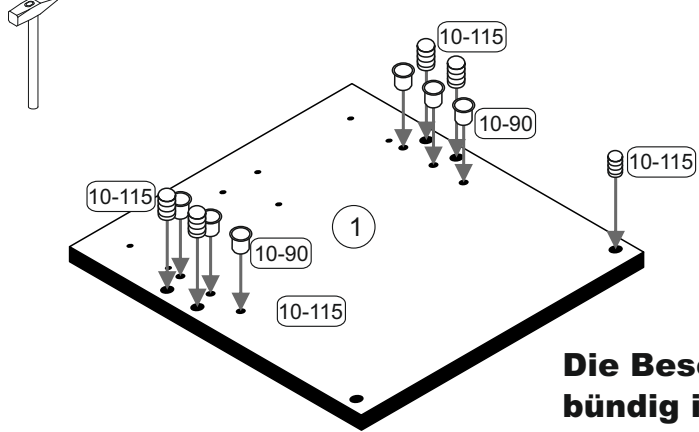

1	10-90		10-110		10-115		M 6
	12x		8x		12x		



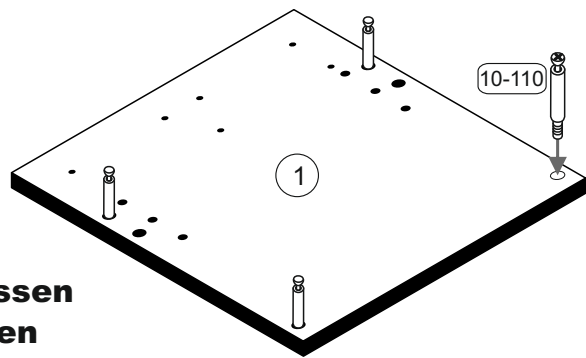

1



Die Beschläge müssen bündig in die Platten eingeschlagen werden.

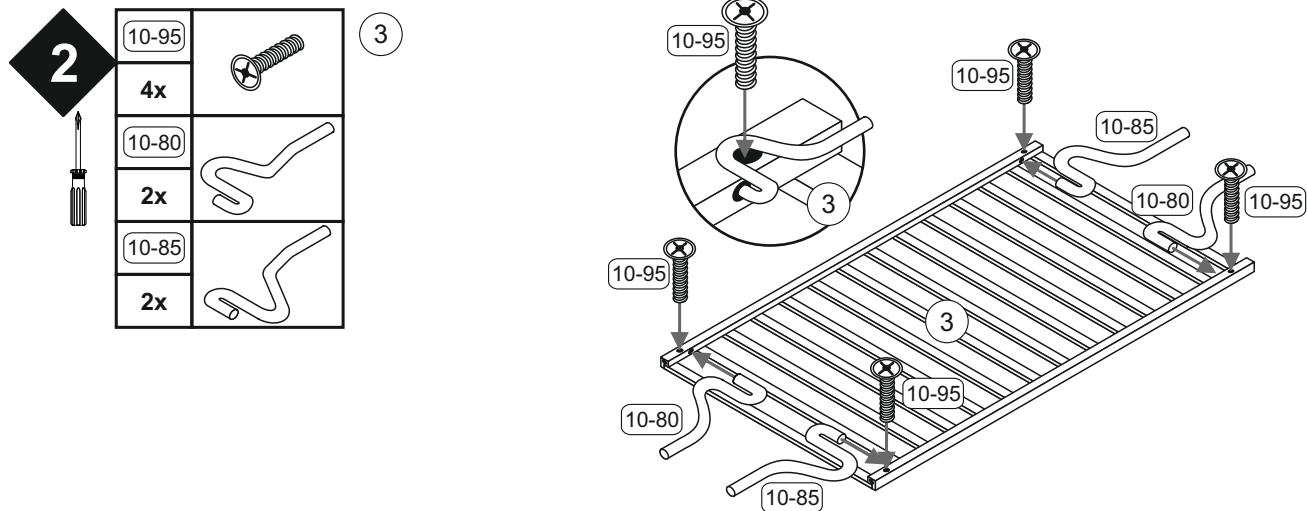

2	10-95		4x
	10-80		
10-85		2x	
10-85			

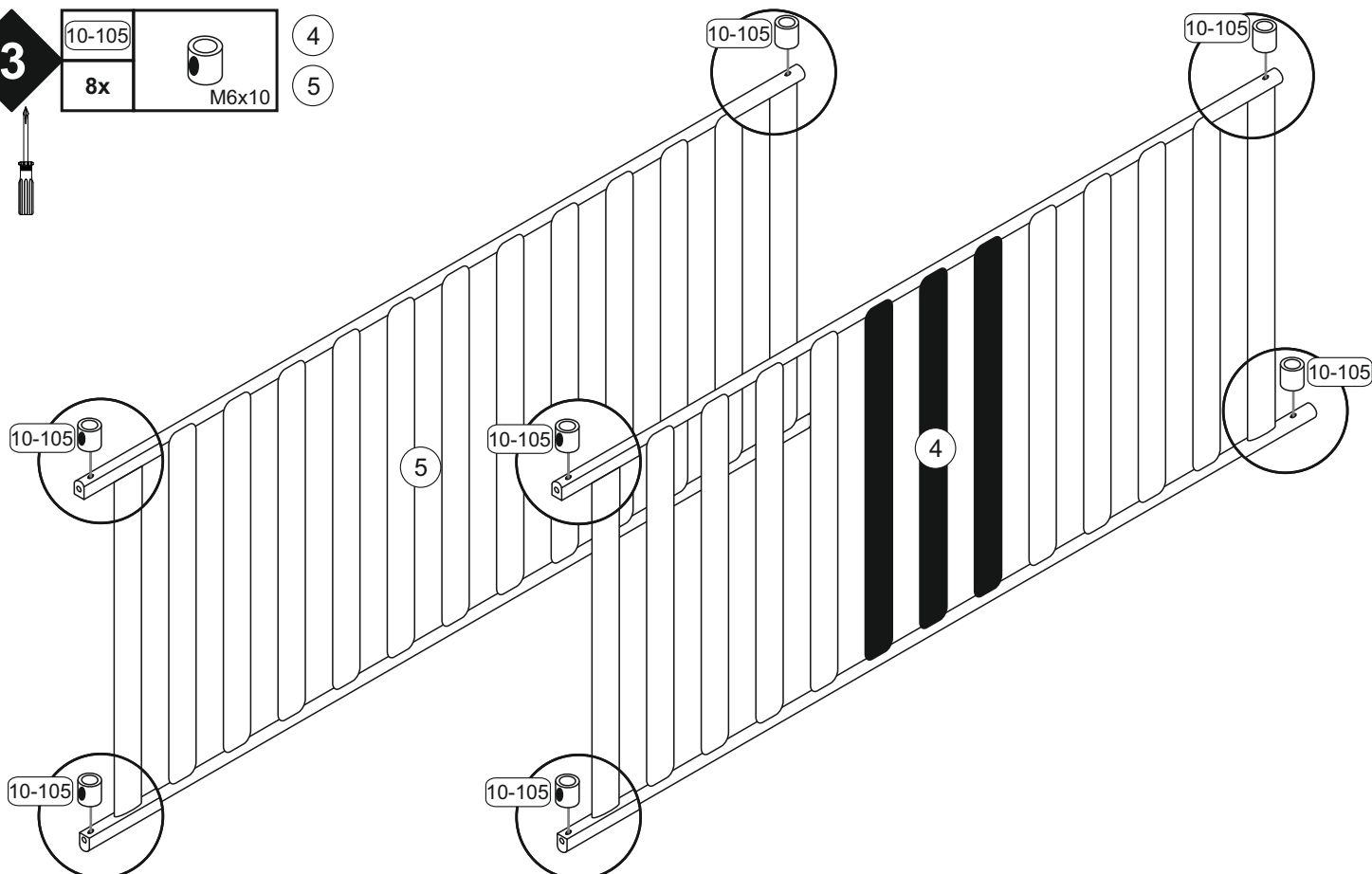

3	10-105		8x	4
	M6x10			5



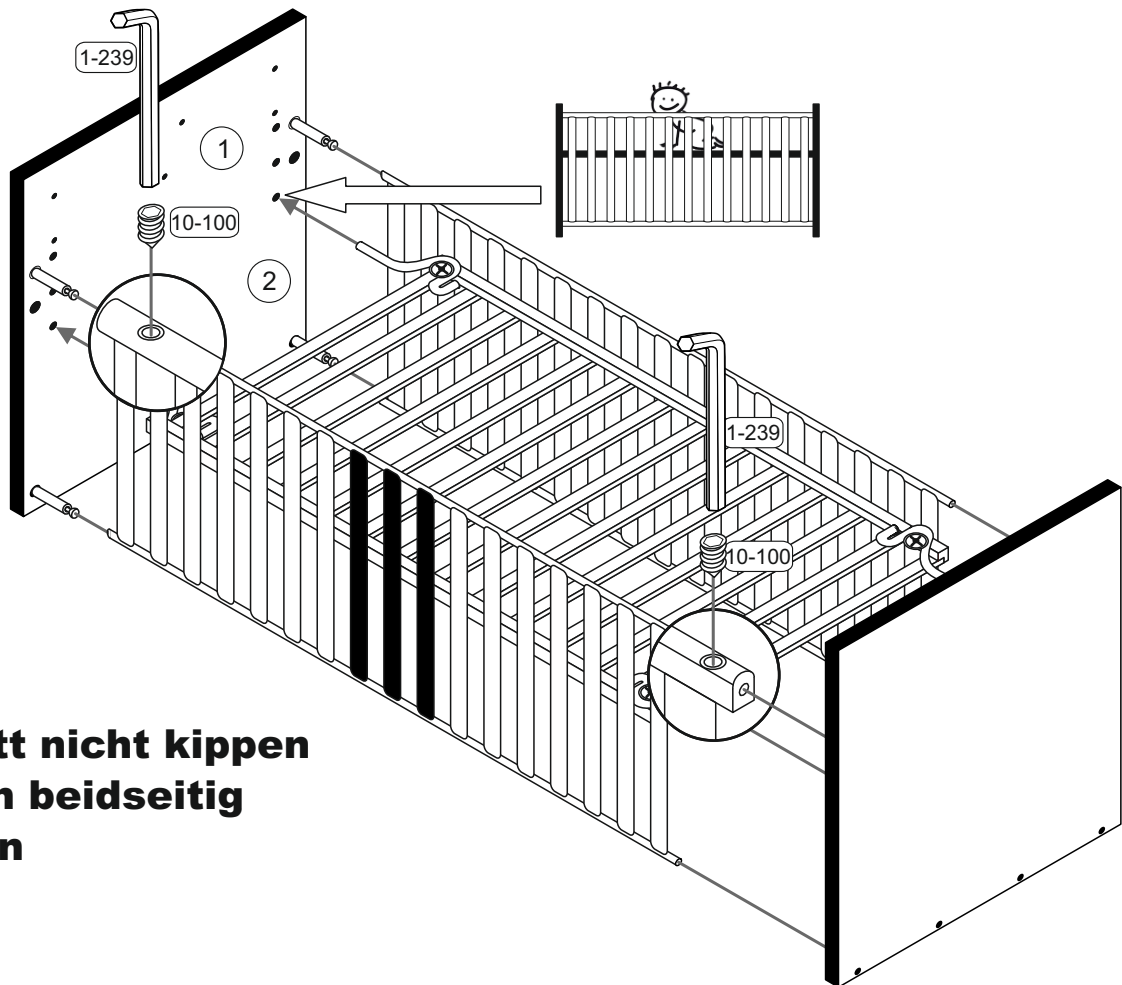

4

1-239		10-100	
1x	SW 3	8x	M6x8



**Das Bett nicht kippen
sondern beidseitig
anheben**

5

2-109		5-130	
8x	10x70	2x	LEIM

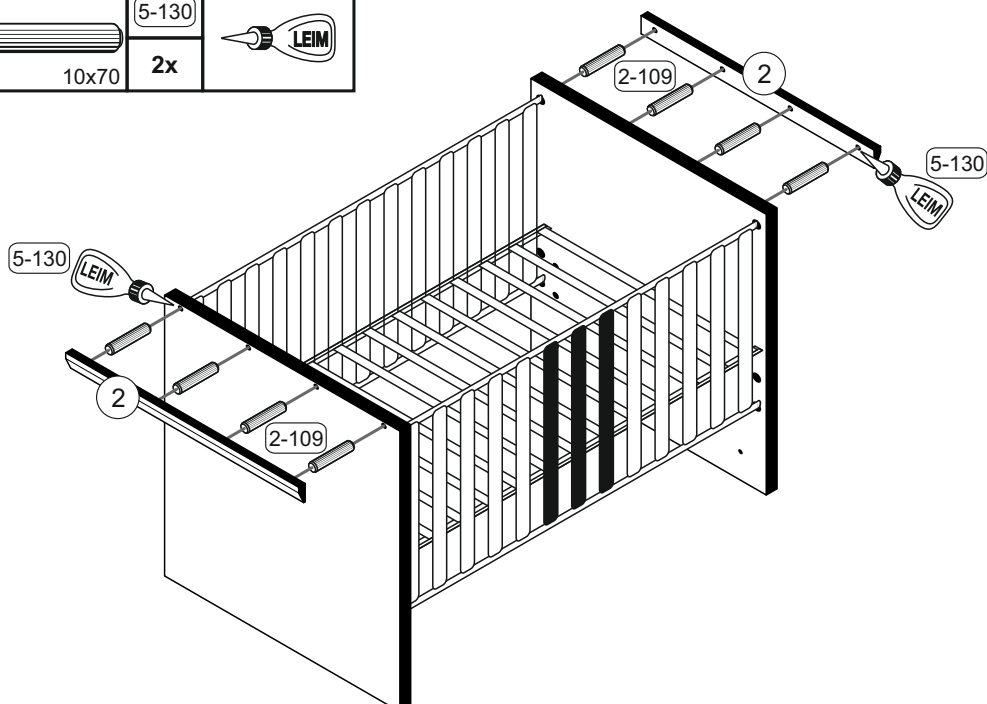

6

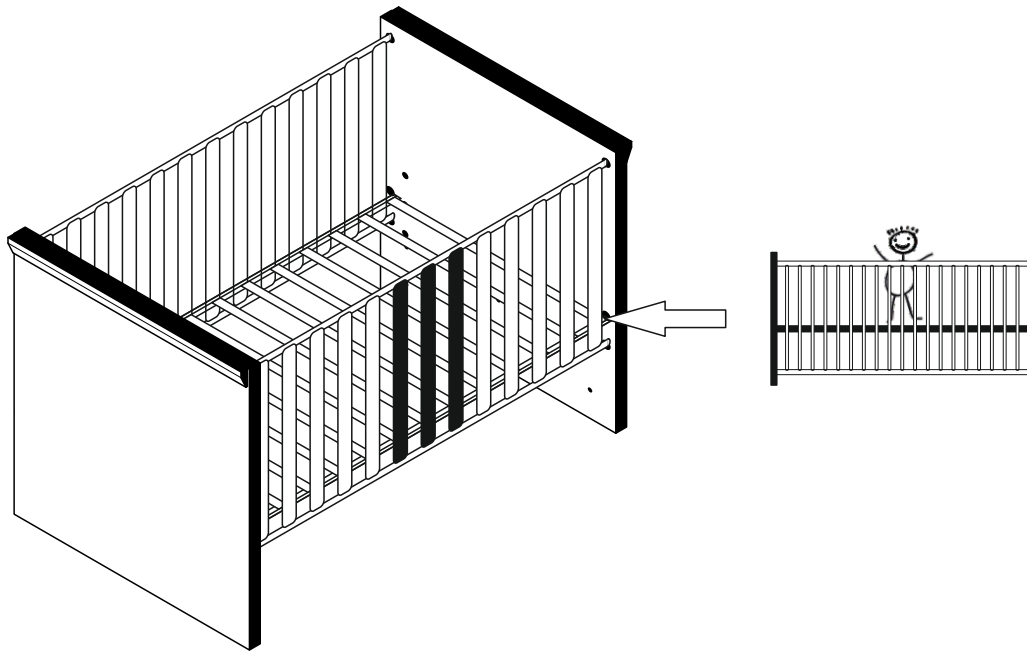

7

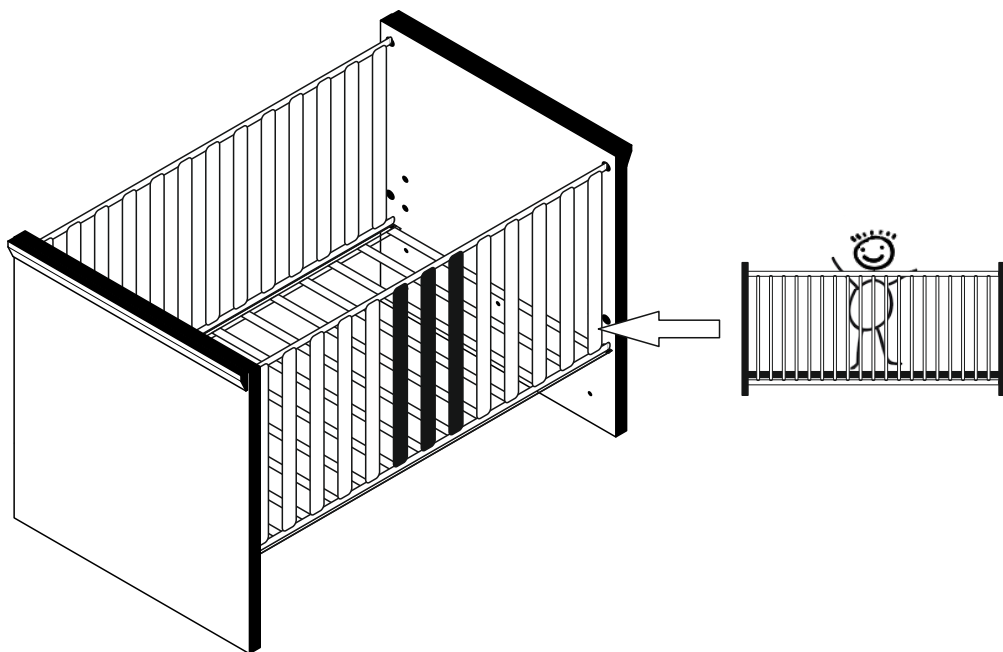



(D) Montageanleitung

(GB) Assembly instructions

(FR) Notice de montage

(TR) Montaj talimatı

(IT) Istruzioni di montaggio

(NL) Handleiding voor de montage

(RU) Инструкция по монтажу

(CZ) Montážní návod

(HU) Szerelési útmutató

(RO) Instrucțiuni de montaj

(PL) Instrukcja montażu

(SK) Návod na montáž

L

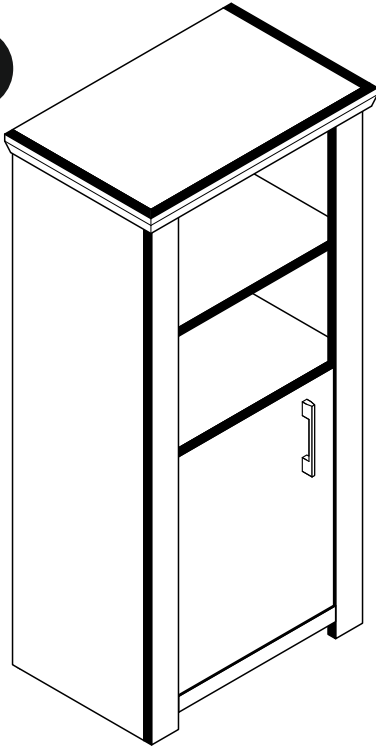

R

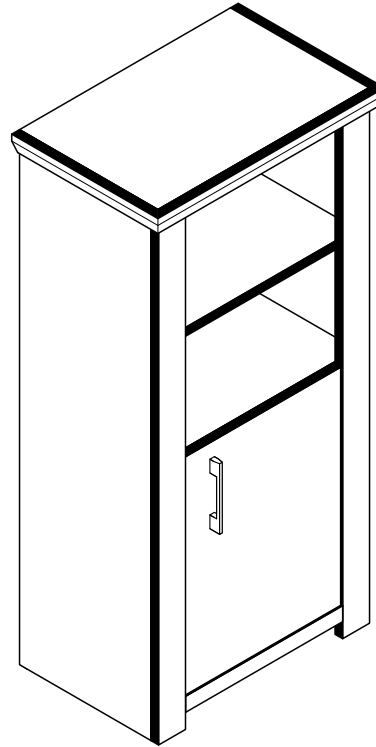

0442-BS_1 Beistellschrank

Service • Assistenza • Dienstverlening • Servis
Servis • Szerviz • Сервисная служба

			<p>Colli 1/1: 1 2 3 4 5 6 7 8 9 10 11 12 13 14 15 16 Beutel 1/3, 2/3, 3/3</p>

Beutel 1/2

1-30 16x 3x16		1-37 1x 4.5x25		1-80 4x 3,5x13		1-90 6x 3,5x20		1-329 2x M4x22		2-10 26x	
2-20 26x		2-160 8x		3-07 1x		3-63 2x		3-64 2x		8-80 1x	

Beutel 2/2

3-130 2x		5-20 6x		5-185 6x		5-190 4x		6-415 1x	
-------------	--	------------	--	-------------	--	-------------	--	-------------	--

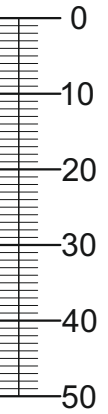

Colli 1/1

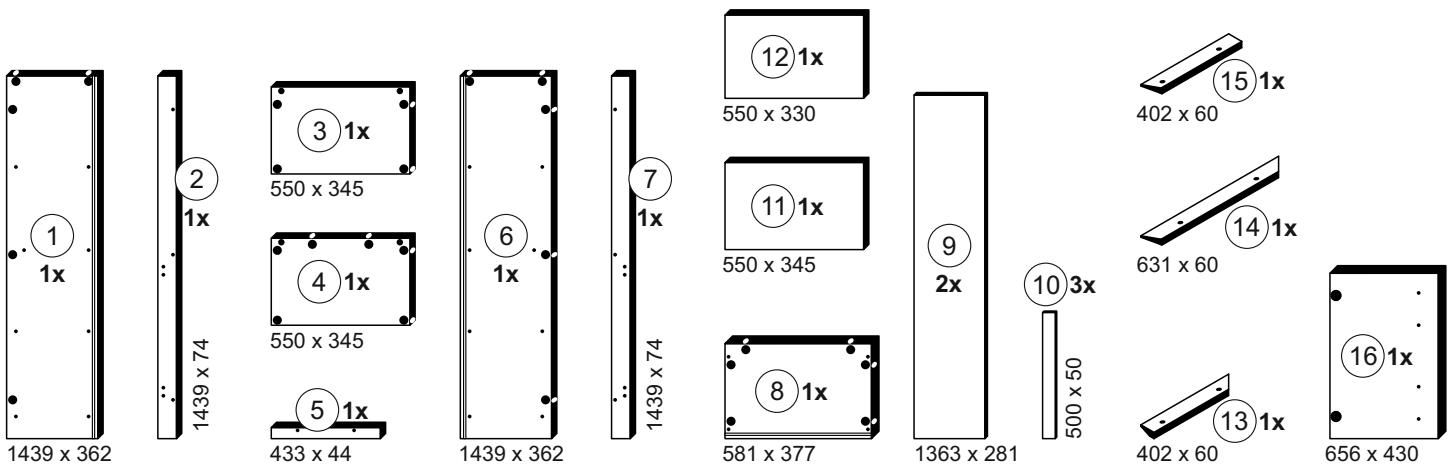

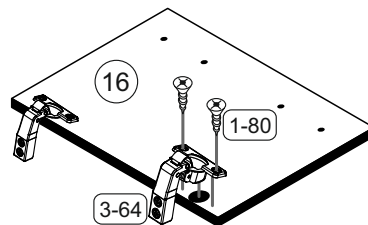
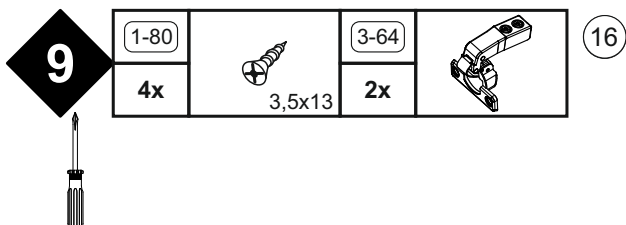
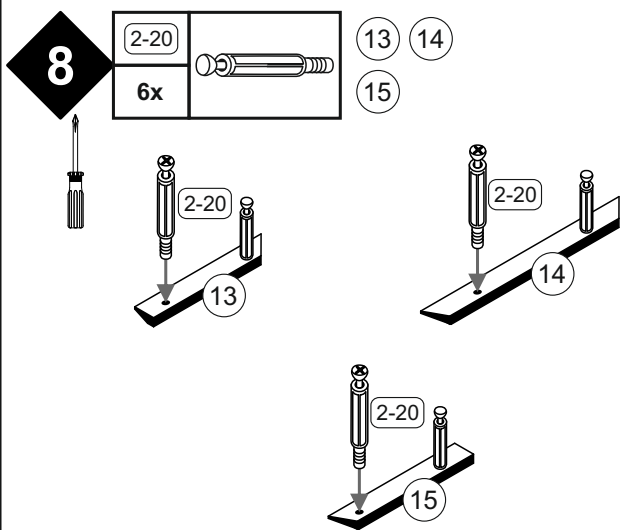
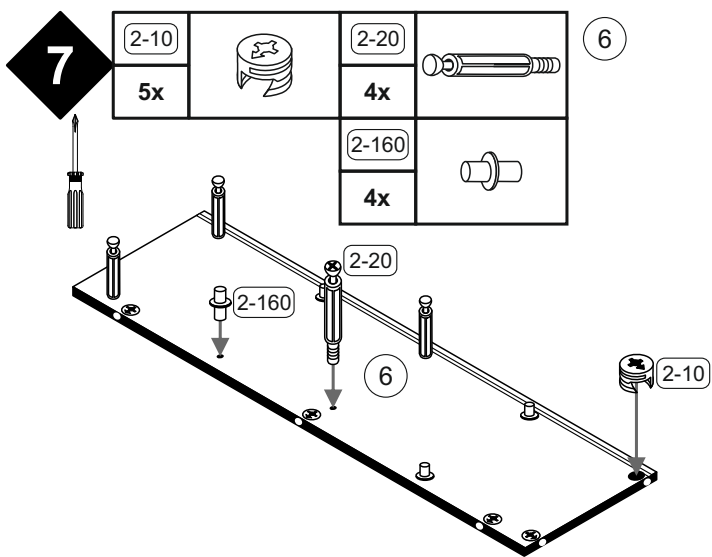
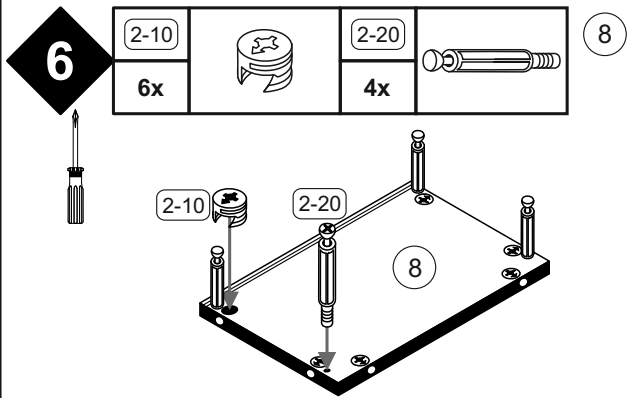
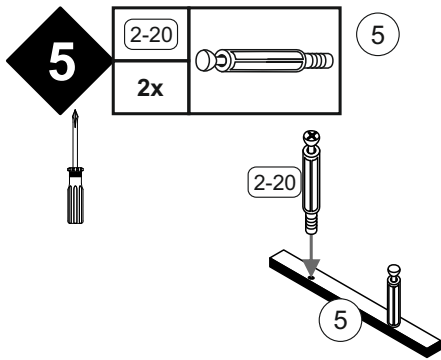
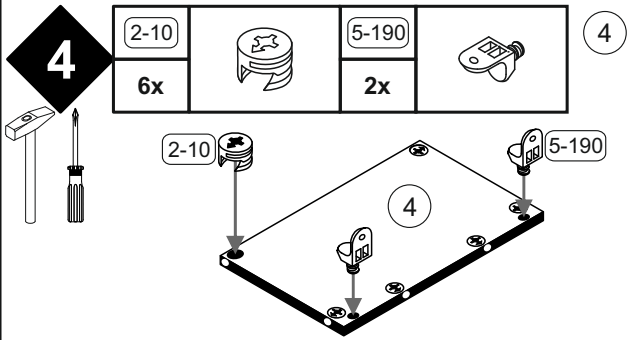
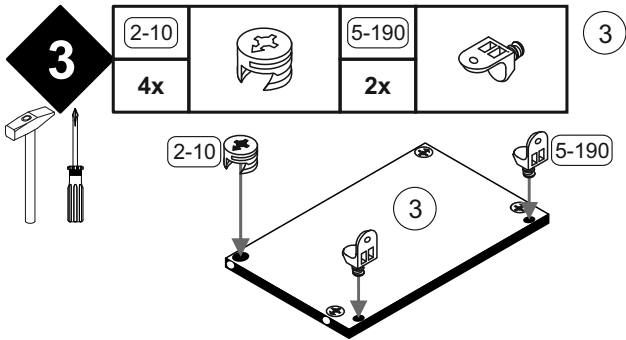
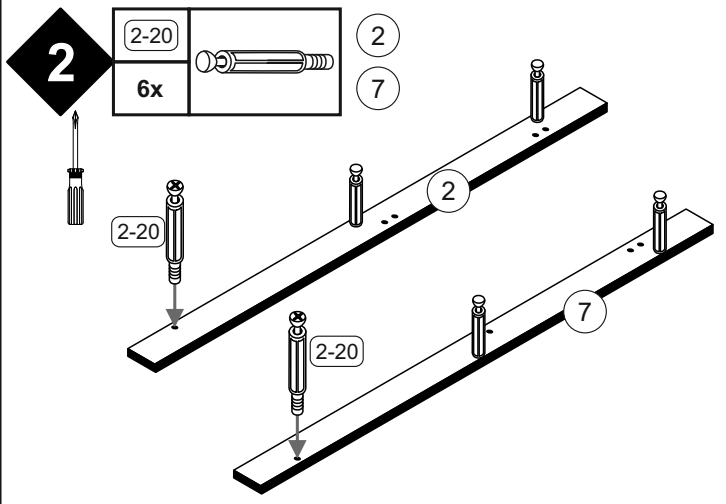
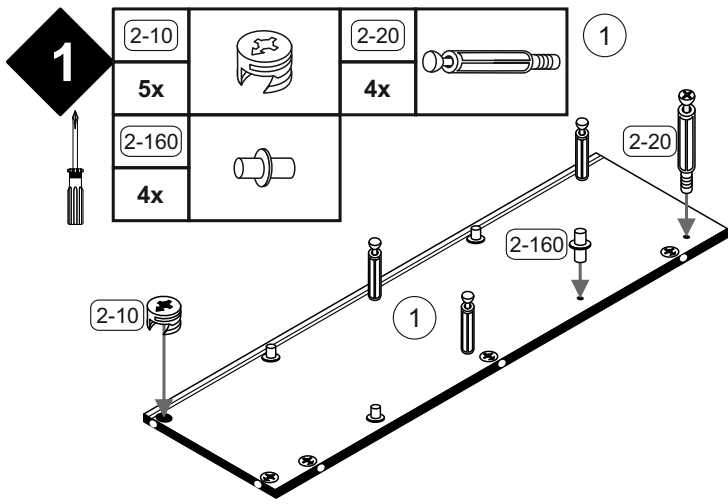

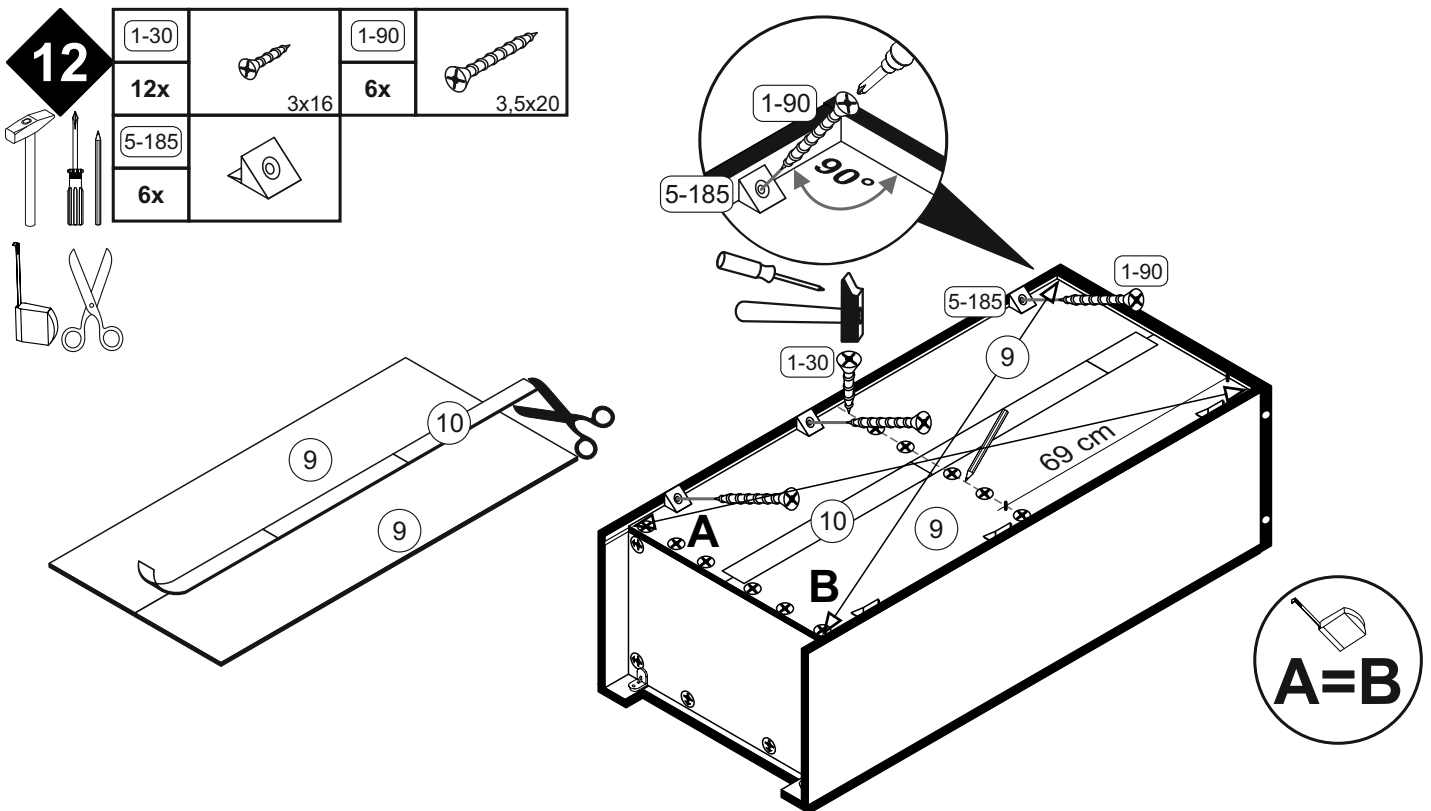
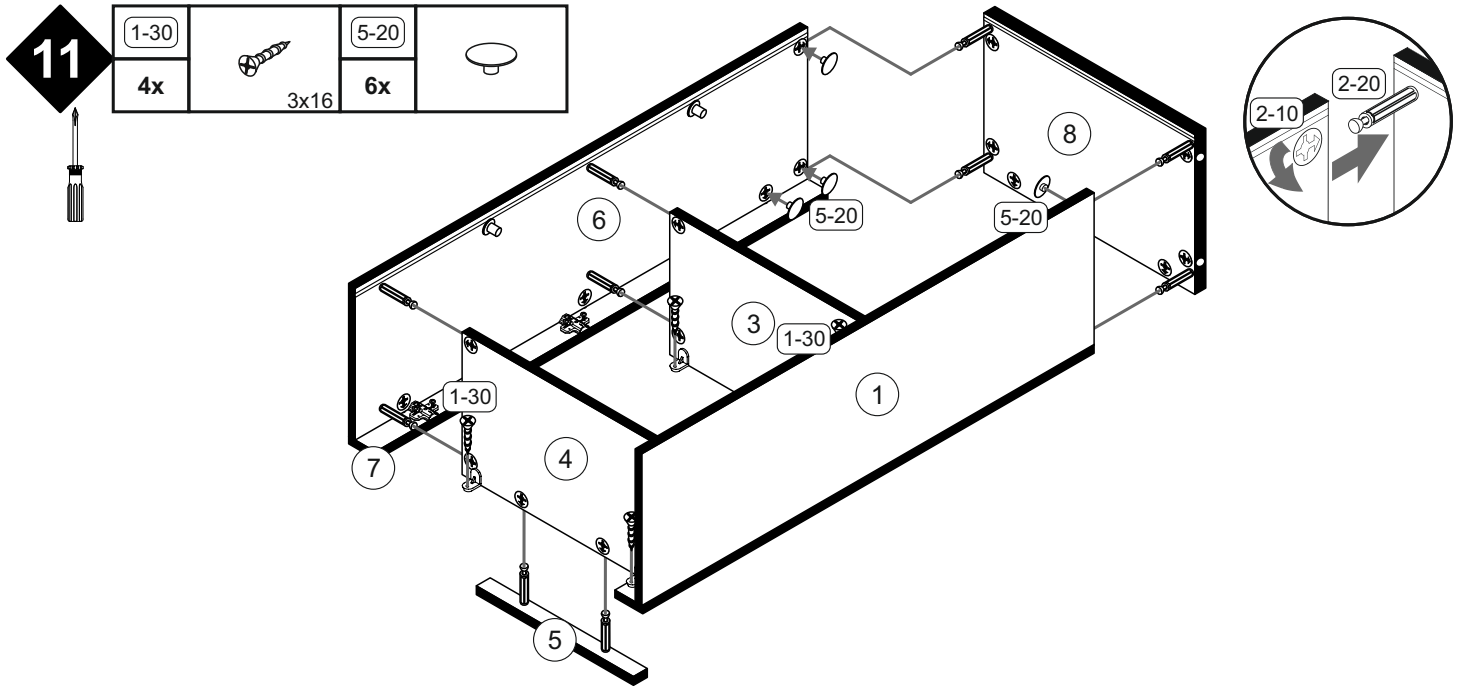
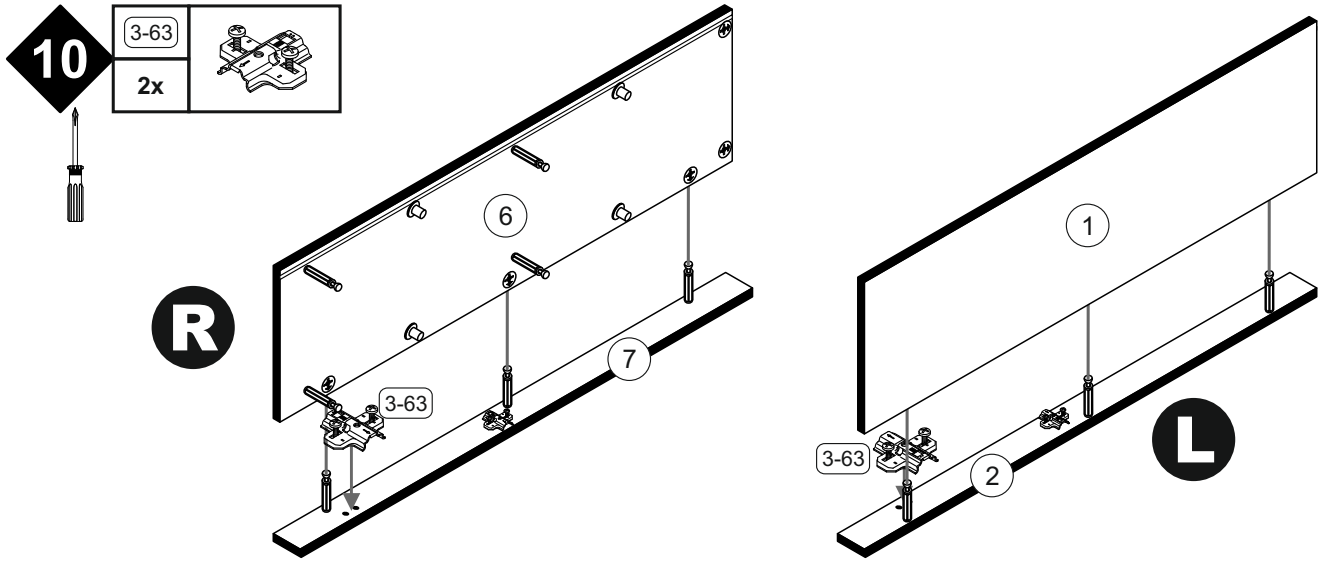

13

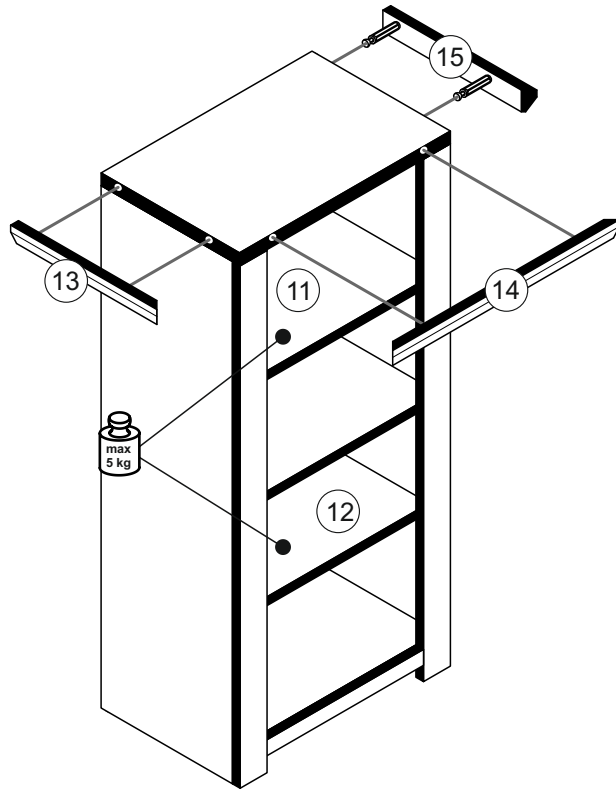

14

1-37		1-329		3-07		3-130		6-415	
1x	4,5x25	2x	M4x22	1x		2x		1x	

L

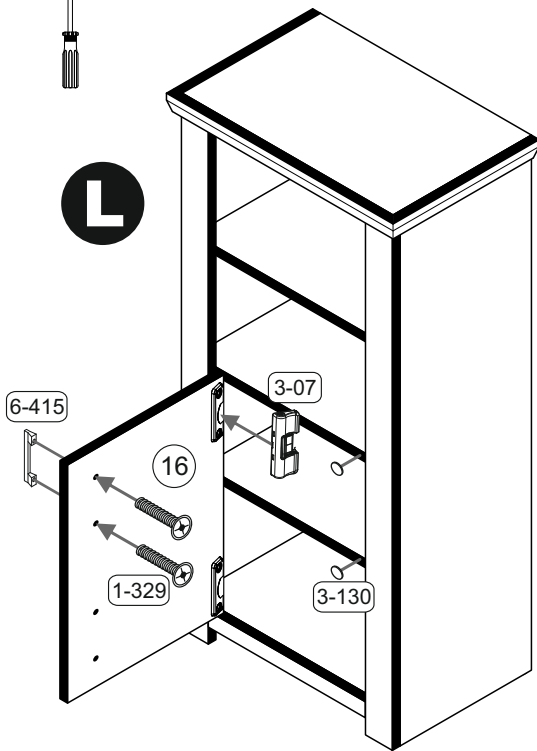

R

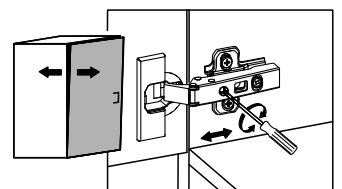
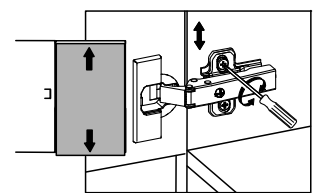
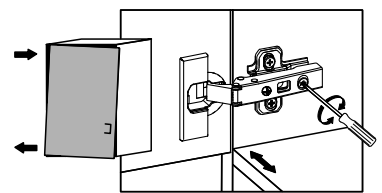
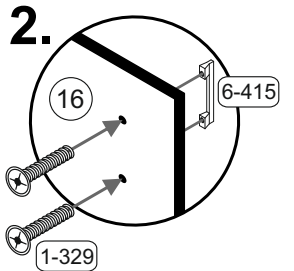
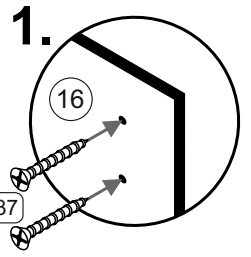
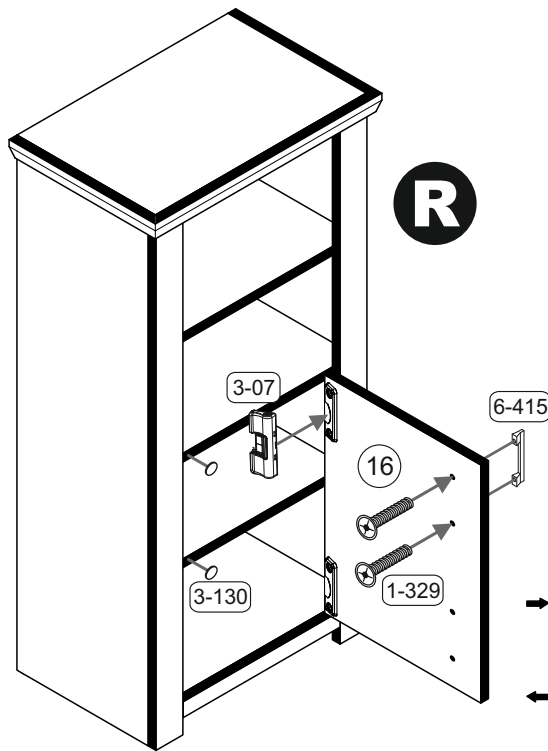

Türen einstellen (Scharniere justieren)
Adjusting the doors (adjusting the hinges)
Régler les portes (ajuster les charnières)
Sistemare le porte (regolare le cerniere)
Deuren instellen (scharnieren afstellen)
Nastawić drzwi (wyregulować zawiasy)
Vyrovnejte dvířka (seřid'te závěsy)
Nastavenie dverí (nastavenie závesov)
Állítsa be az ajtókat (állítsa be a zsanérokot)
Reglare ușii (ajustare balamale)
Kapıların ayarlanması (mentşelerin seviye ayarı)
Регулировка дверей (регулировка шарнира)

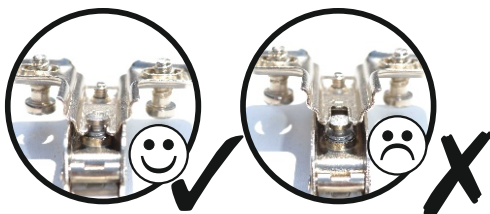

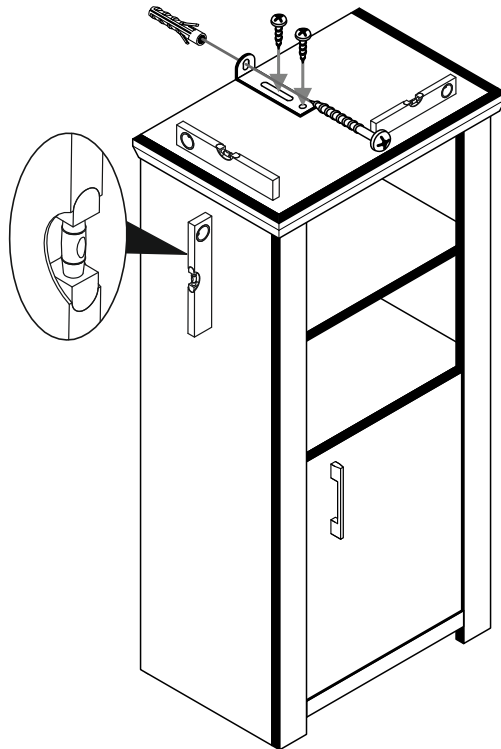
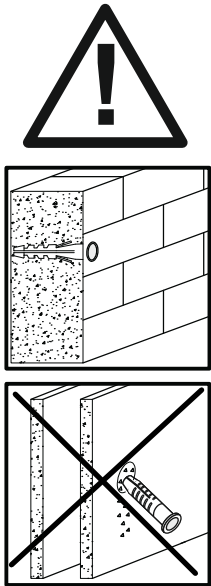
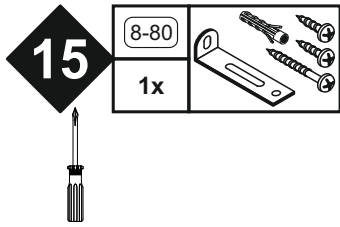

Achtung • Attention • Attenzione • Opgelet • Uwaga • Pozor • Figyelem • Atenție • Dikkat • Внимание	
(D)	Wandbefestigung dient als Kippschutz - unbedingt anbringen! Bei einigen Wandtypen kann ein Spezialdübel erforderlich sein!
(GB)	The wall fastening serves to prevent tipping - be absolutely sure to mount it! For certain wall types, a special wall plug may be necessary!
(FR)	La fixation murale sert de protection contre le basculement – à installer impérativement ! Pour certains types de murs il faut des chevilles spéciales !
(TR)	Duvardaki sabitleme, devrilmeye karşı bir emniyet tedbiridir ve mutlaka monte edilmelidir! Bazı duvar tiplerinde bunun için özel bir dübel gerekli olabilir!
(IT)	Il fissaggio alla parete serve da protezione anti-ribaltamento – attaccarla assolutamente! Per alcune strutture di parete può essere necessario un tassello speciale!
(NL)	Bevestiging aan de muur dient als kantelbescherming – zeker en vast bevestigen! Bij enkele muurtypes is een speciale plug misschien vereist!
(RU)	Обязательно установите крепление на стене во избежание опрокидывания! Для некоторых типов стен может потребоваться специальный дюбель!
(CZ)	Montáž na stěnu slouží jako ochrana proti převrnutí – bezpodmínečně umístěte! U některých typů stěn může být zapotřebí speciální hmoždinka!
(HU)	A terméket a falhoz kel rögzíteni, különben az felborulhat! Egyes faltípusoknál speciális tiplit kell használni!
(RO)	Sistemul de fixare la perete servește ca protecție la răsturnare - de montat obligatoriu! Pentru unele tipuri de pereți este posibil să fie necesar un diblu special!
(PL)	Mocowanie do ściany jest jednocześnie zabezpieczeniem przed przewróceniem – koniecznie zamontować! Do niektórych rodzajów ścian koniecznie zastosować specjalne kołki mocujące.
(SK)	Upevnenie na stenu slúži ako ochrana proti prevráteniu – bezpodmienečne použite! Pre niektoré druhy stien môže byť potrebná špeciálna hmoždinka!



(D) Montageanleitung

(GB) Assembly instructions

(FR) Notice de montage

(TR) Montaj talimatı

(IT) Istruzioni di montaggio

(NL) Handleiding voor de montage

(RU) Инструкция по монтажу

(CZ) Montážní návod

(HU) Szerelési útmutató

(RO) Instrucțiuni de montaj

(PL) Instrukcja montażu

(SK) Návod na montáž



0442-KS_32 Kleiderschrank

Service • Assistenza • Dienstverlening • Serwis
Servis • Szerviz • Сервисная служба

			<p>Colli 1/3: ① ② ④ ⑨ ⑪ ⑫ ⑬ ⑭ ⑮ ⑰ ⑱</p> <p>Colli 2/3: ⑤ ⑲ ⑳ ㉑ ㉒ ㉓ ㉔ ㉕ ㉖ Beutel 3/3</p> <p>Colli 3/3: ③ ⑥ ⑦ ⑧ ⑩ ⑯ ㉗ ㉘ ㉙ ⑳ Beutel 1/3, 2/3</p>

Beutel 1/3

1-10 4x 6,3x50	1-30 60x 3x16	1-37 1x 4,5x25	1-70 4x 3x30	1-80 26x 3,5x13	1-90 6x 3,5x20
1-200 8x 6,3x13	1-329 10x M4x22	2-08 8x h=10mm	2-10 43x h=12mm	2-20 51x	2-114 4x
2-160 12x	3-11 3x	3-42 3x 8er	8-80 1x		

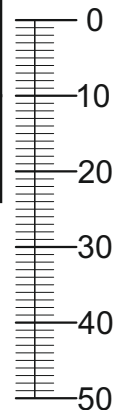

Beutel 2/3

3-07 3x	3-63 6x	3-64 6x
------------	------------	------------

Beutel 3/3

3-130 10x	5-185 6x	5-190 2x	6-415 5x
--------------	-------------	-------------	-------------

Colli 1/3

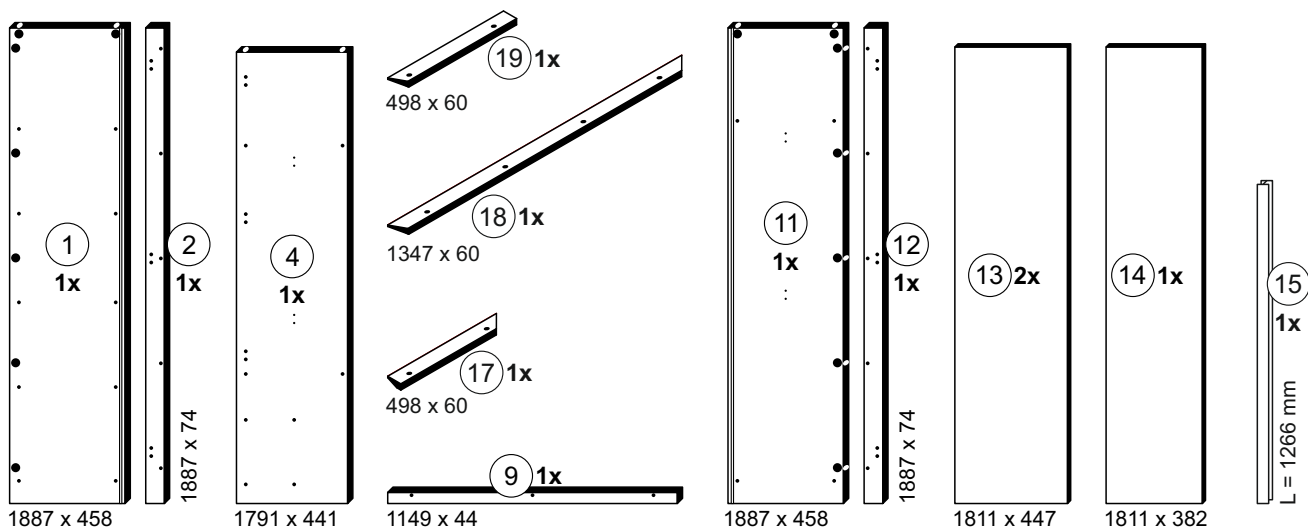

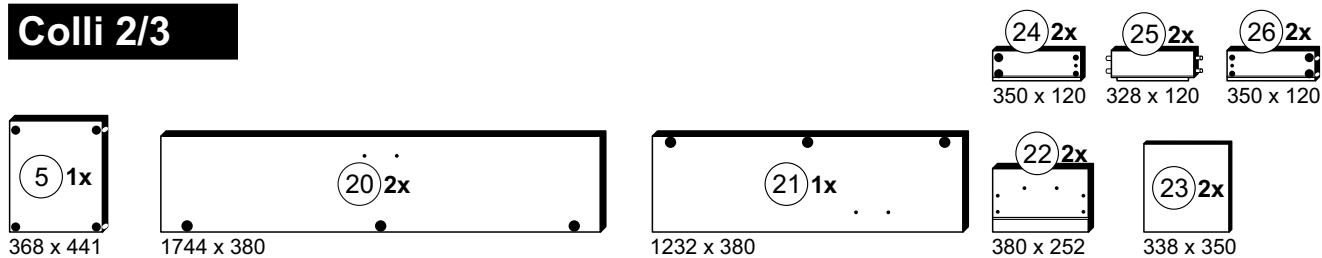

Colli 2/3

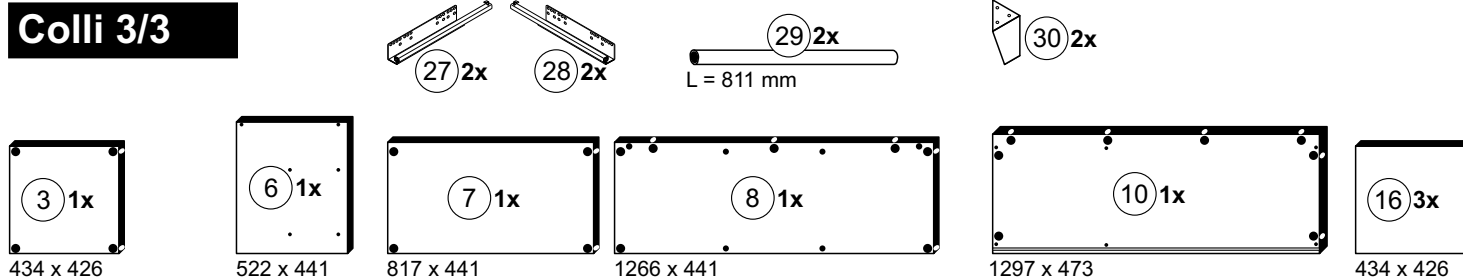

Colli 3/3



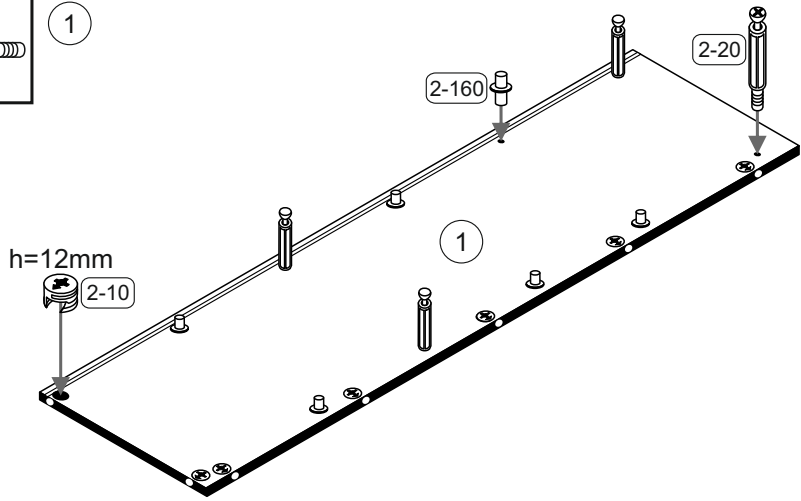

1

2-10		2-20	
7x		4x	
2-160			
6x			



2

2-20		2
10x		12
3-63		
6x		

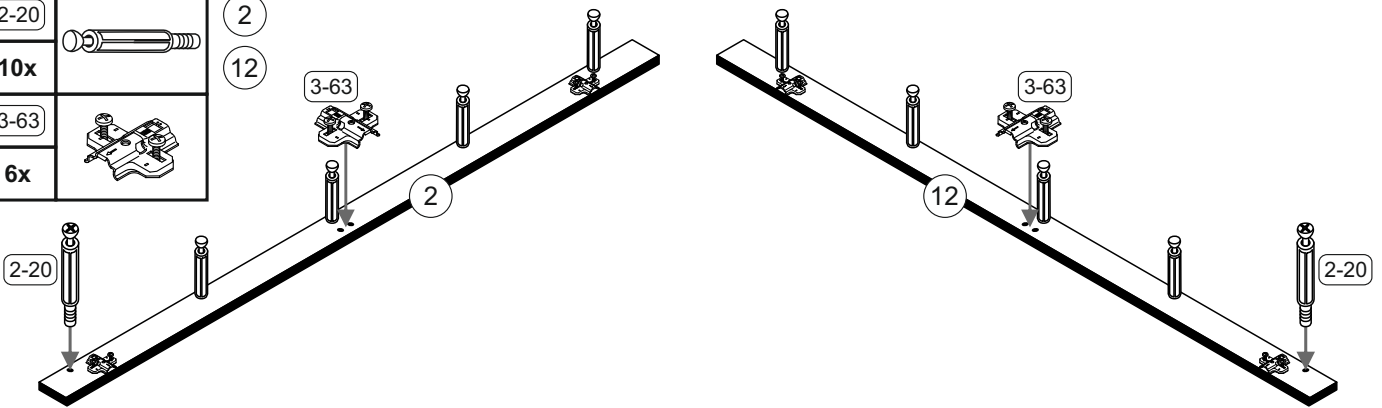

3

2-10		3
4x		

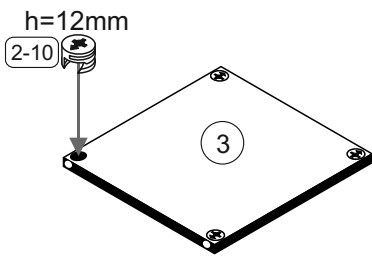





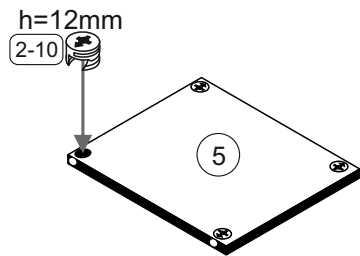

4

2-10		5
4x		



5

1-80		1-200		2-10		2-20		2-160		4
4x	3,5x13	4x	6,3x13	2x		6x		6x		27
				2-114		3-11				
				2x		3x				

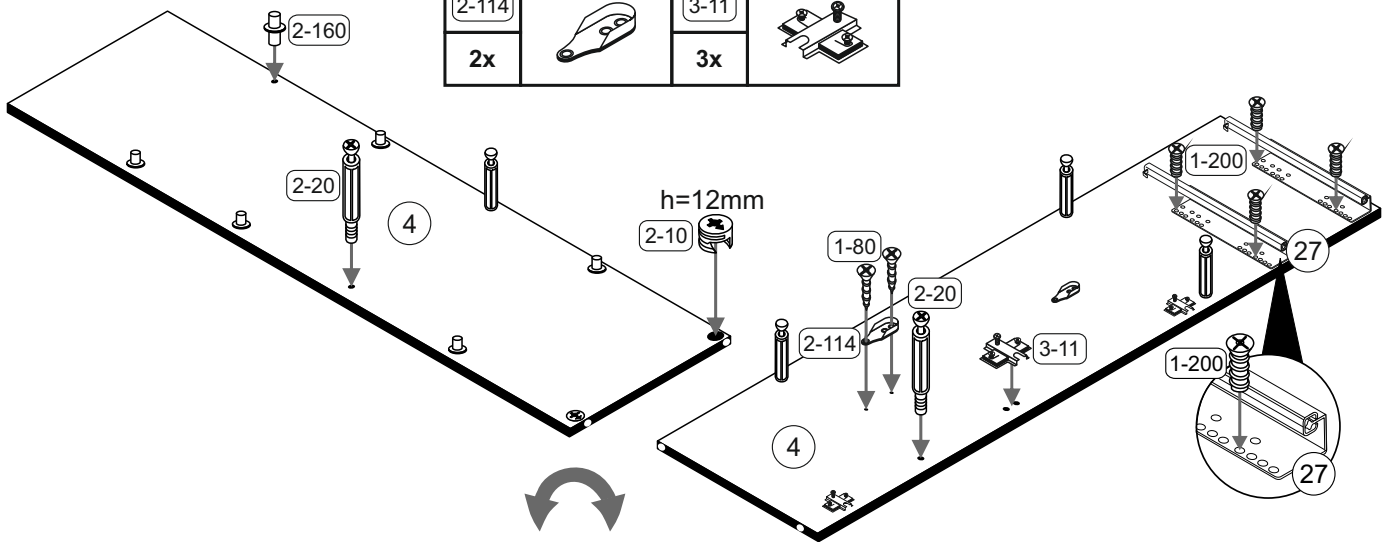

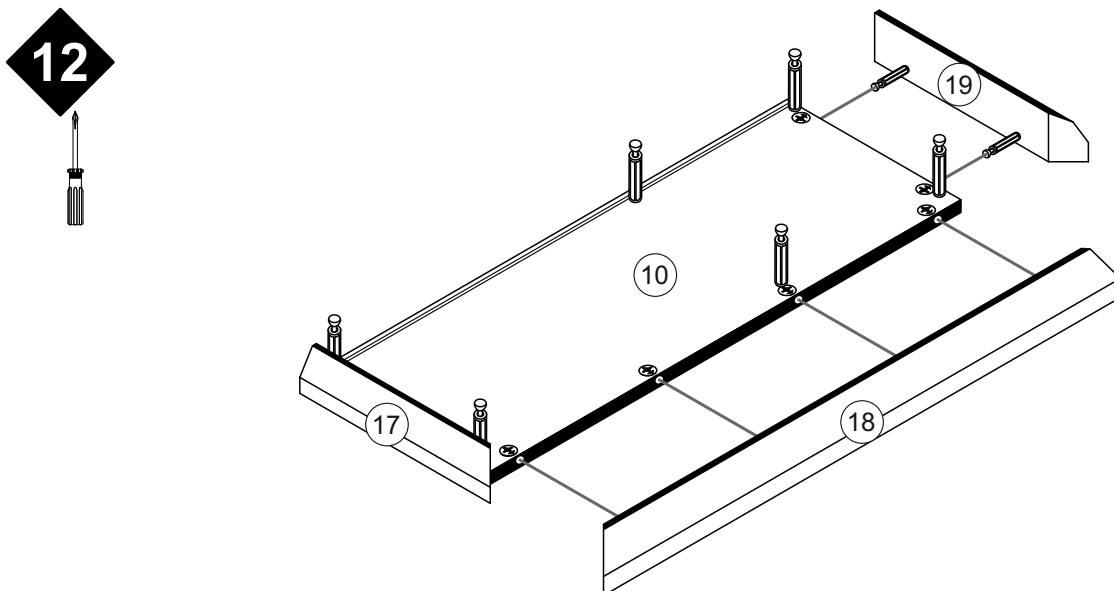
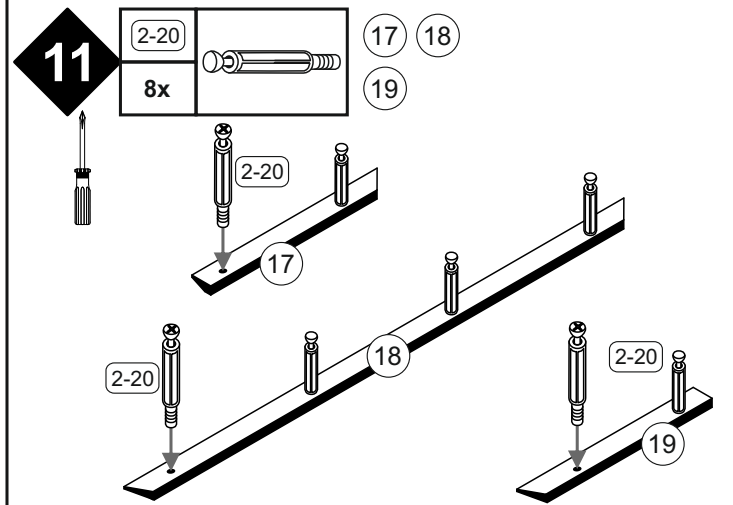
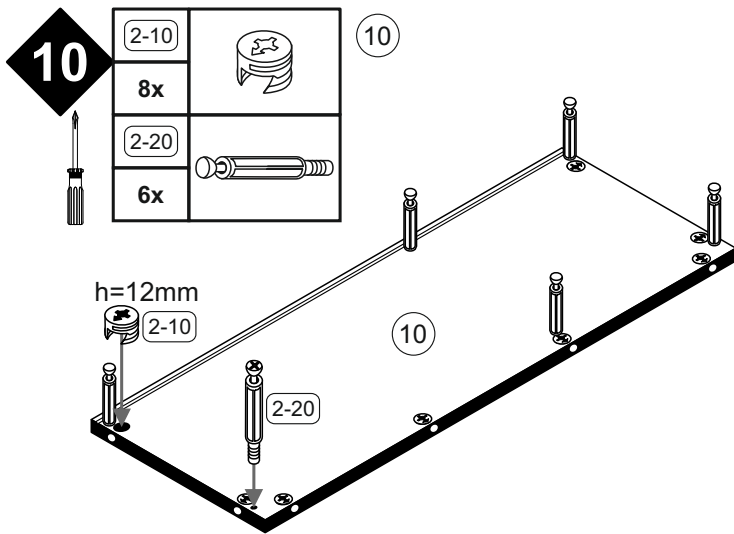
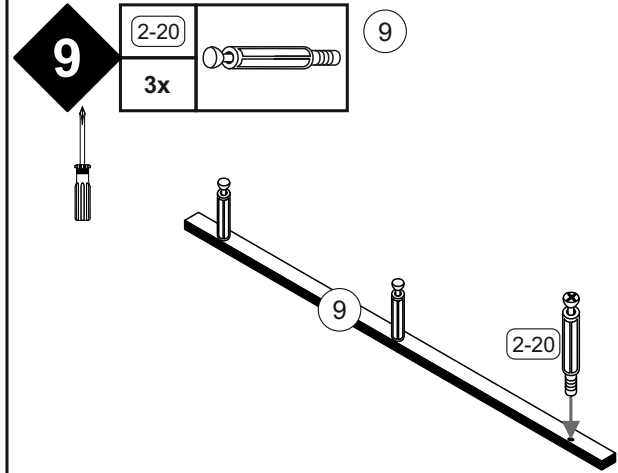
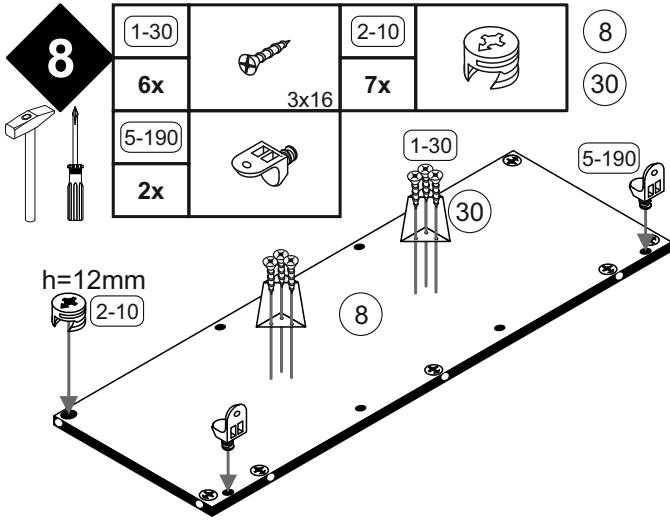
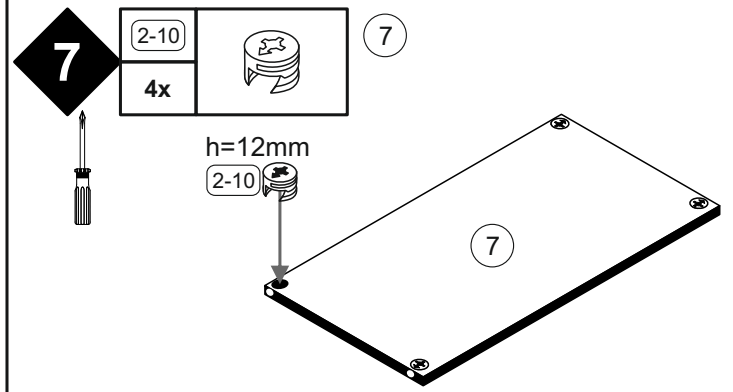
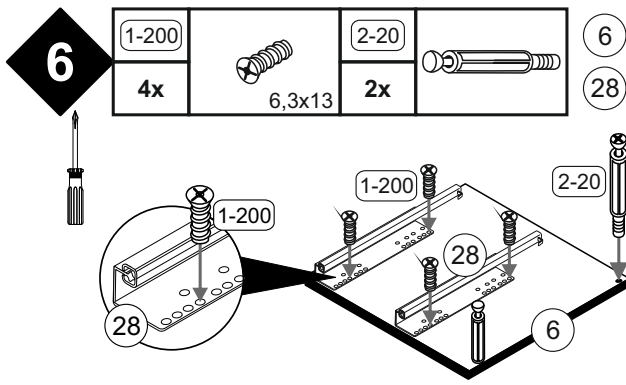

13

1-80		2-10	
4x	3,5x13	7x	
2-20		11	
4x			
2-114			
2x			

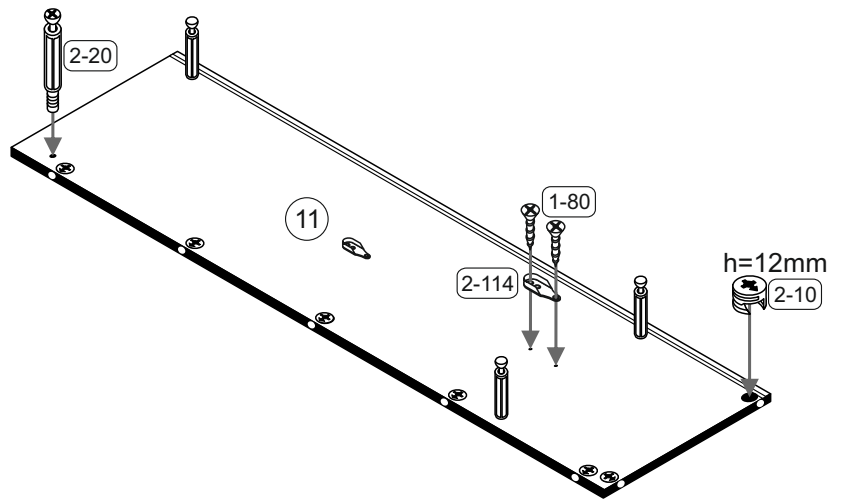

14

1-37		1-80		1-329		M4x22	3-42		3-64		6-415	
1x	4,5x25	18x	3,5x13	6x			3x	8er	6x		3x	

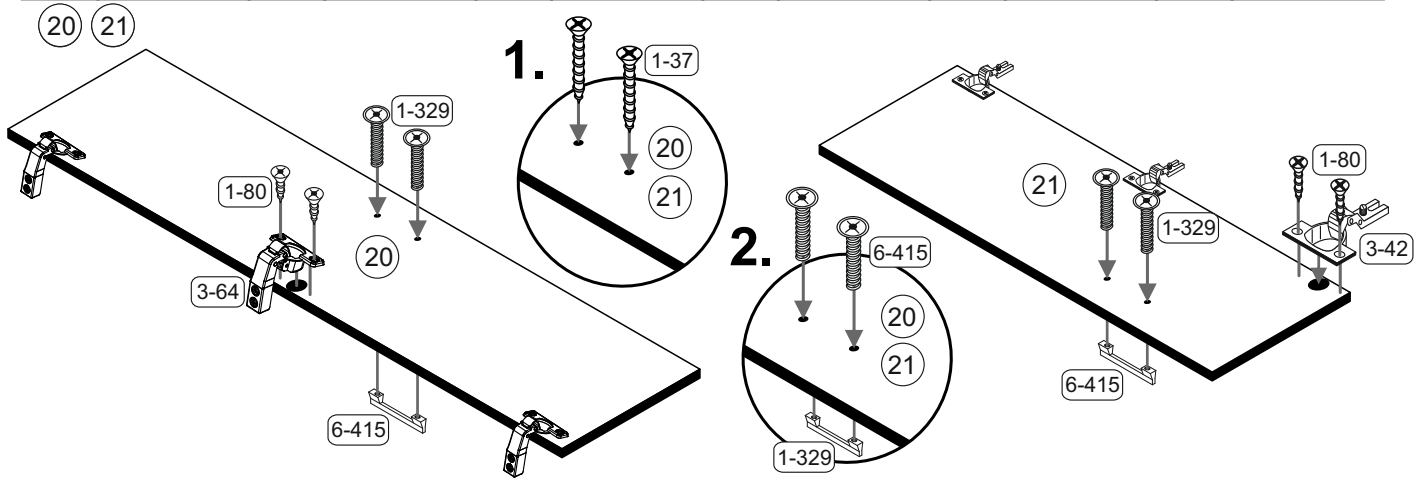

15

1-37		1-329		M4x22	2-08		2-20		3-130		6-415	
1x	4,5x25	4x			8x		8x		4x		2x	

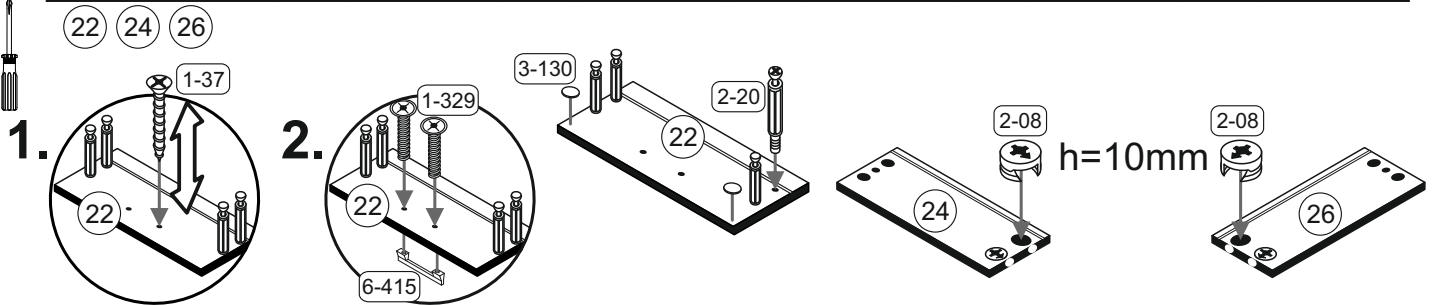

16

1-70		22	23	24
4x	3x30	25	26	

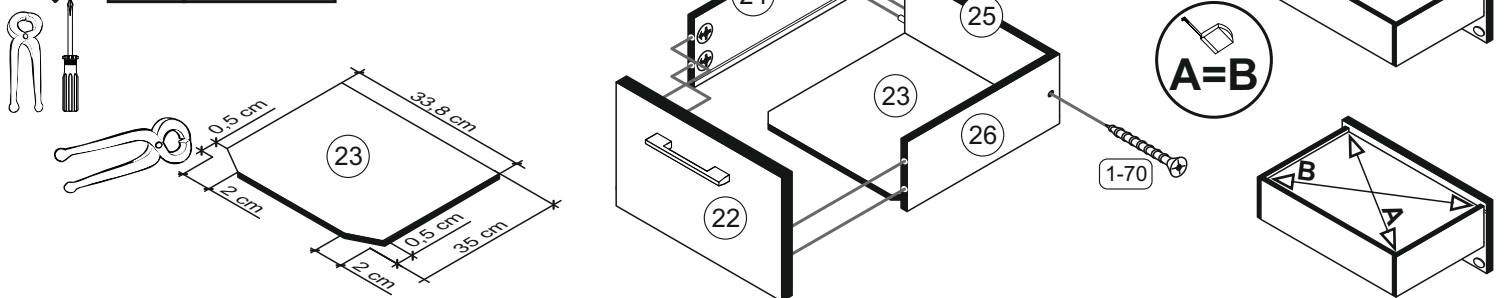

17

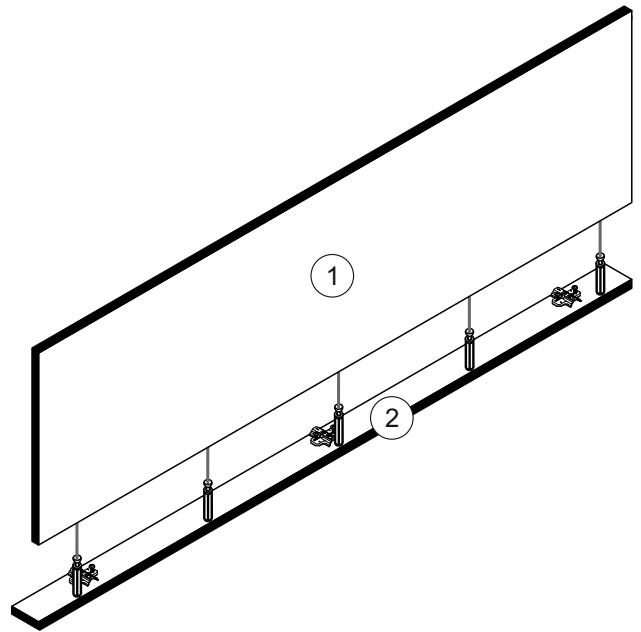
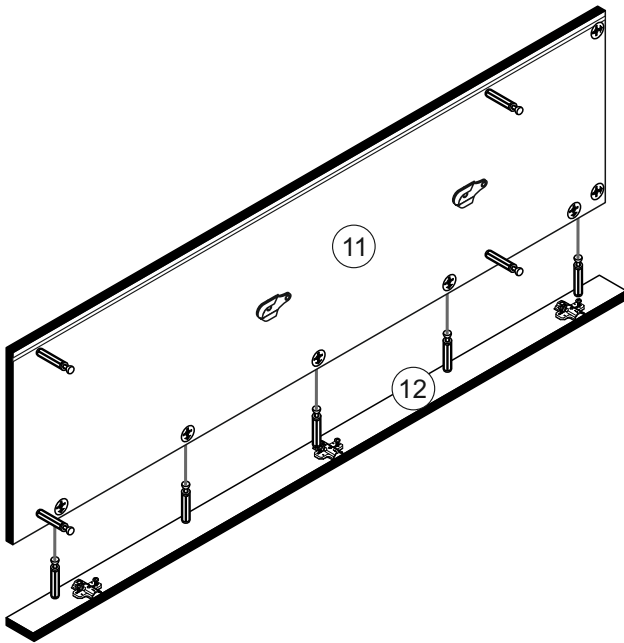

18



1-10
4x
6,3x50

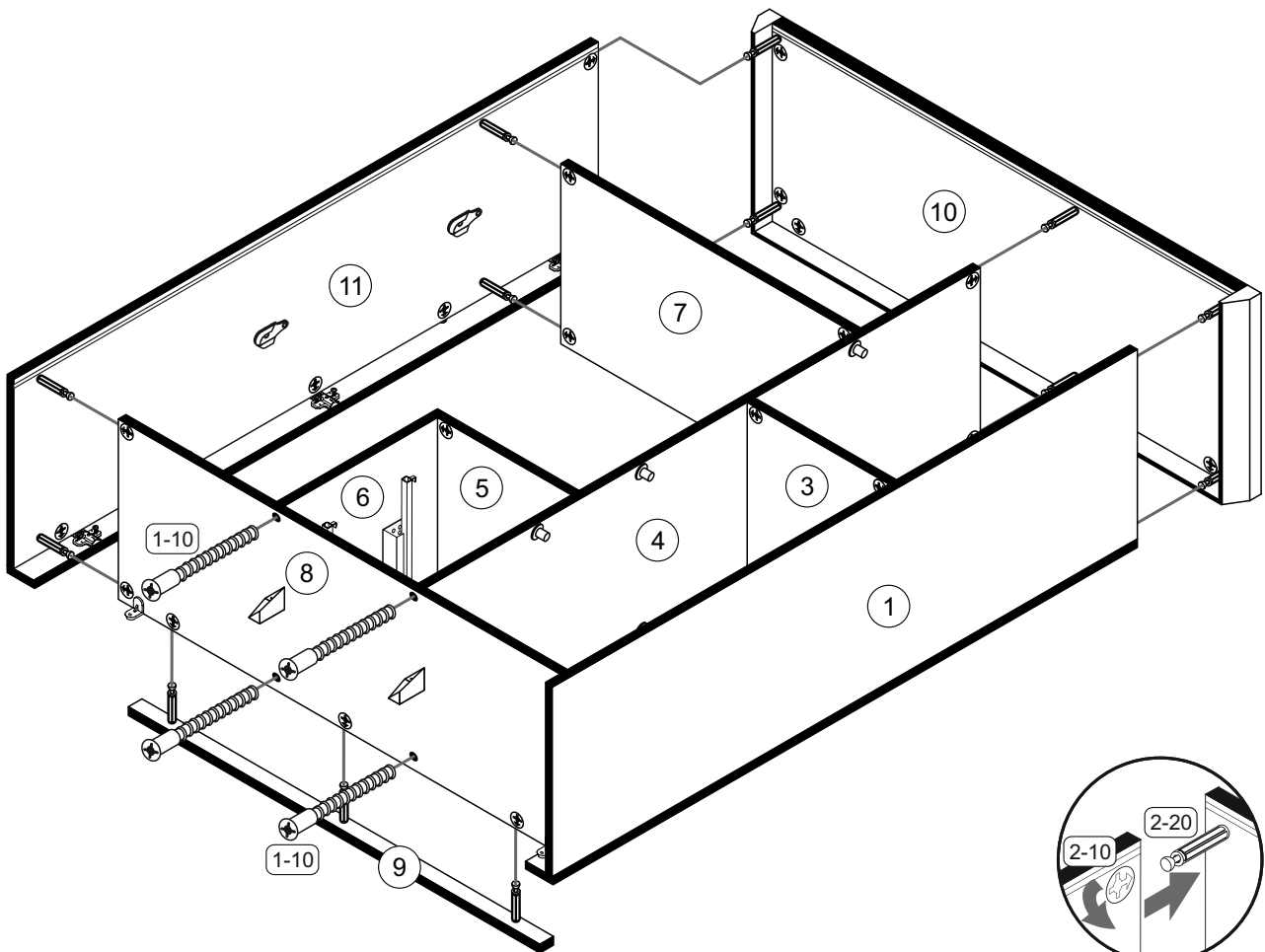
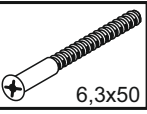

19	1-30		
	54x		3x16
	1-90		
	6x		3,5x20
	5-185		
	6x		

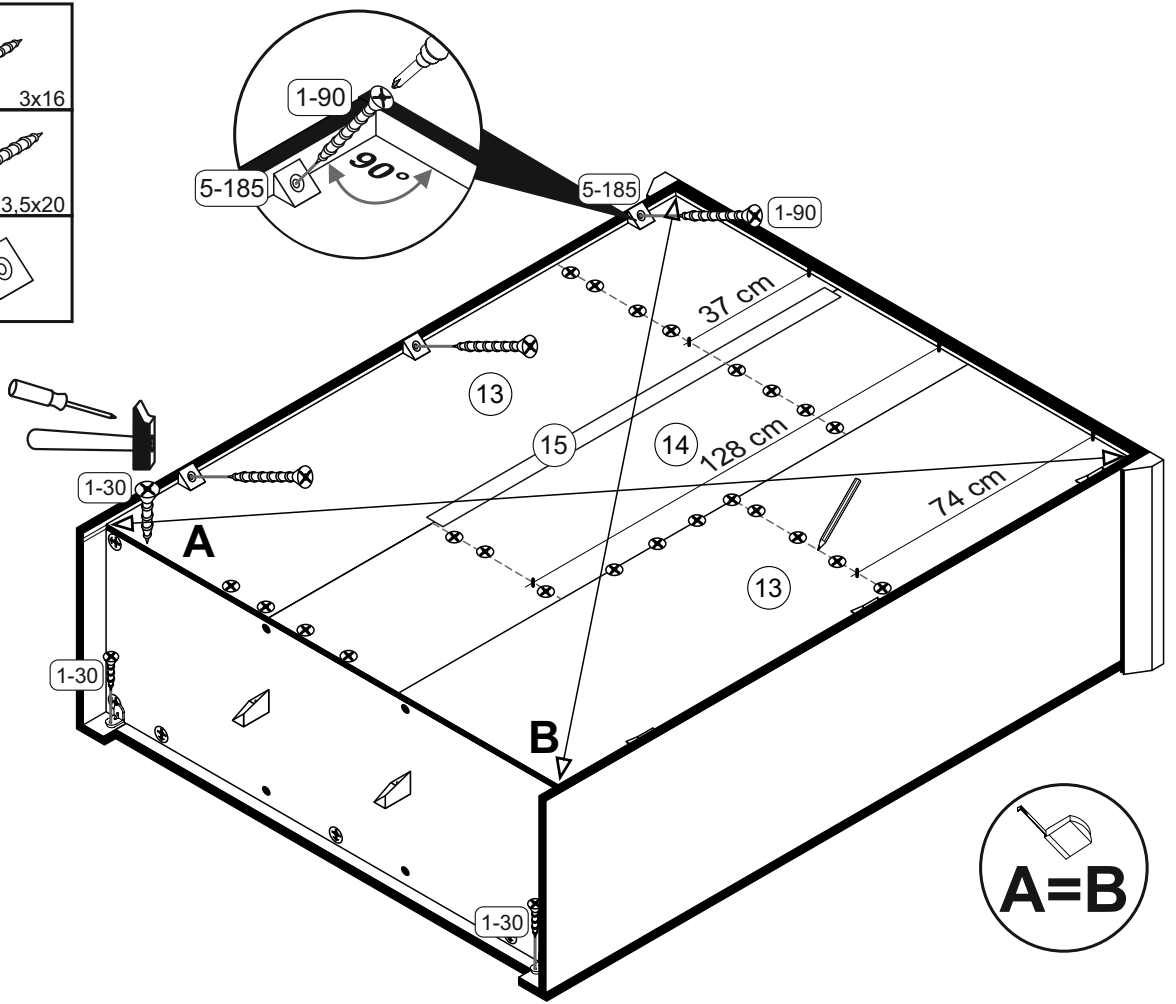

20

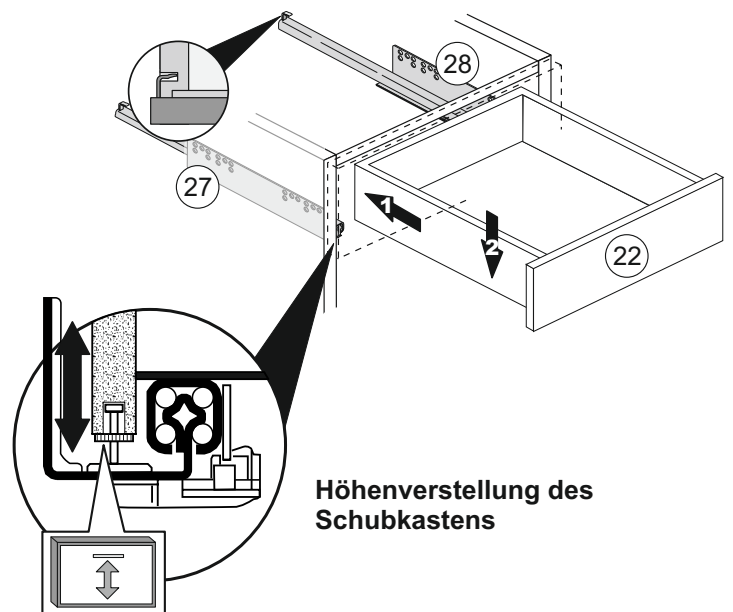
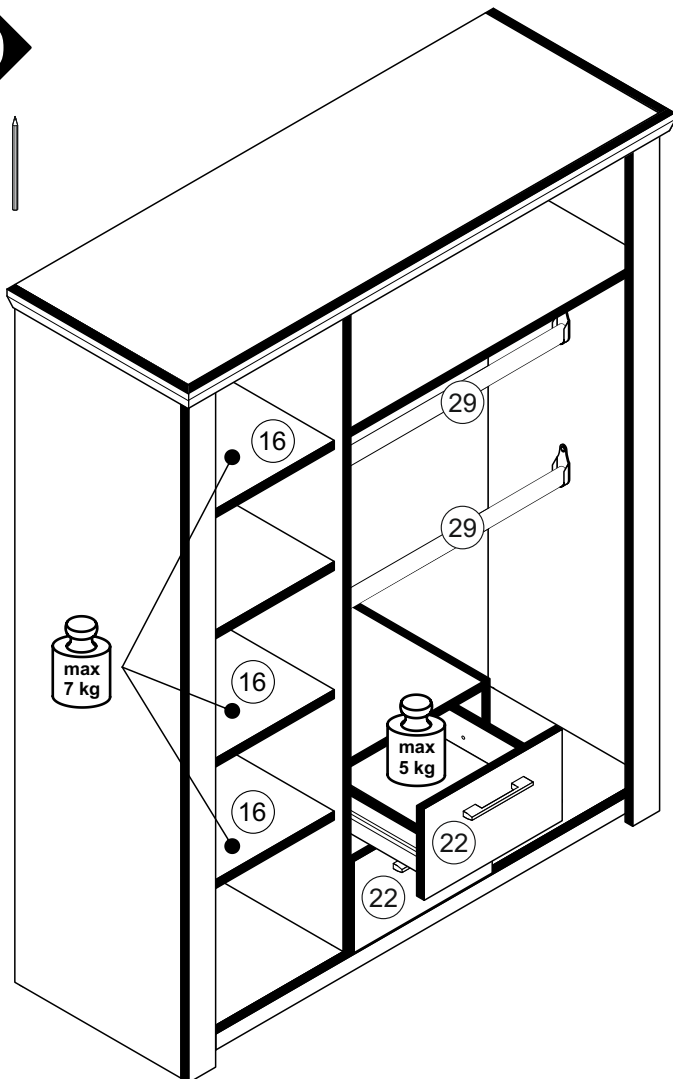

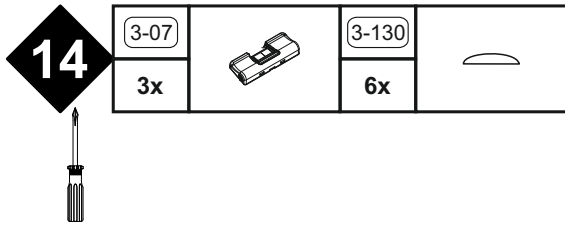

Montage der Tüрдämpfung

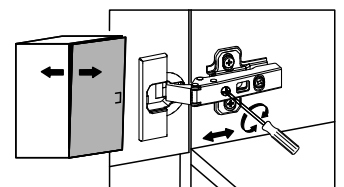
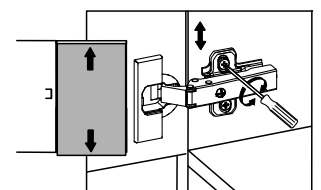
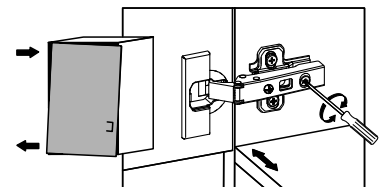
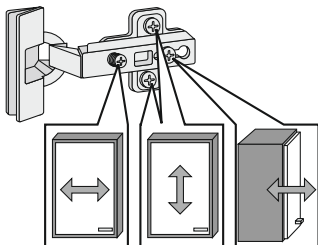
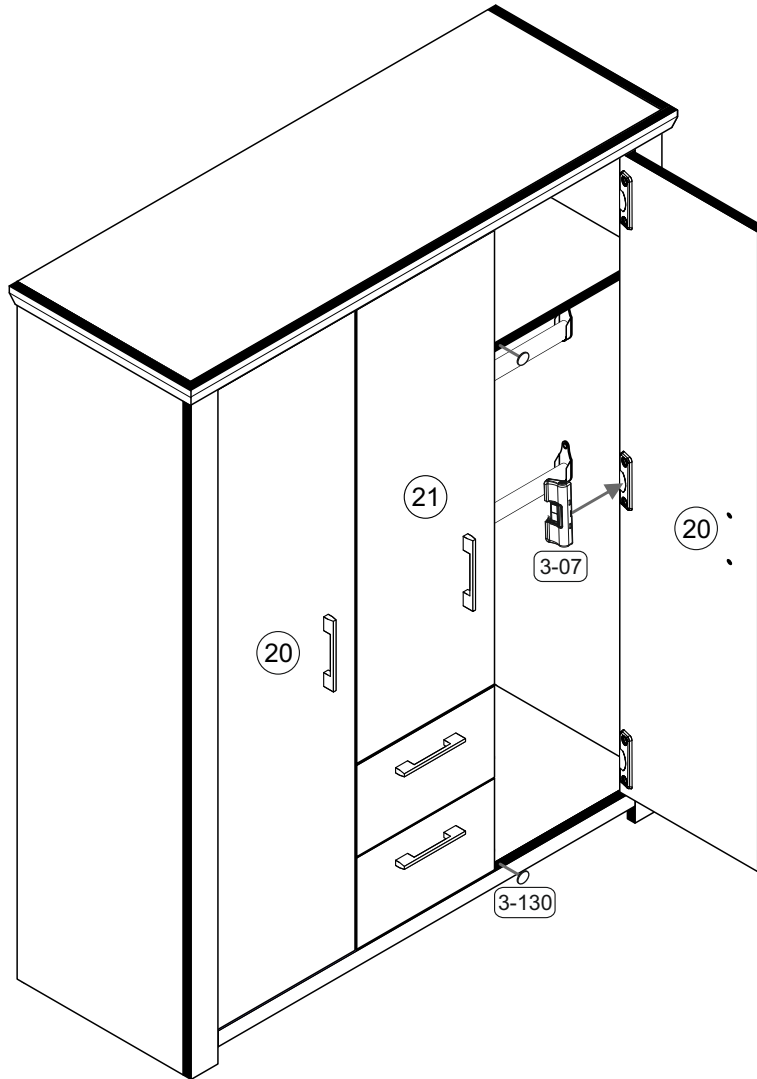
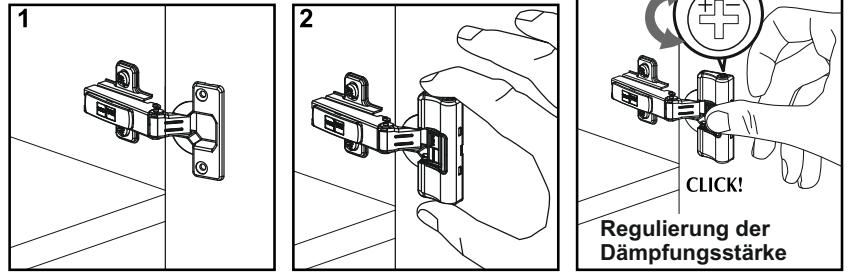

Türen einstellen (Scharniere justieren)
 Adjusting the doors (adjusting the hinges)
 Régler les portes (ajuster les charnières)
 Sistemare le porte (regolare le cerniere)
 Deuren instellen (scharnieren afstellen)
 Nastawić drzwi (wyregulować zawiasy)
 Vyrovnajte dviřka (seřid'te zävěsy)
 Nastavenie dverí (nastavenie zävěsov)
 Állítsa be az ajtókat (állítsa be a zsanérokot)
 Reglare uși (ajustare balamale)
 Kapıların ayarlanması (mentşelerin seviye ayarı)
 Регулировка дверей (регулировка шарнира)

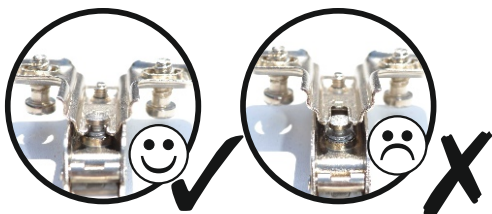

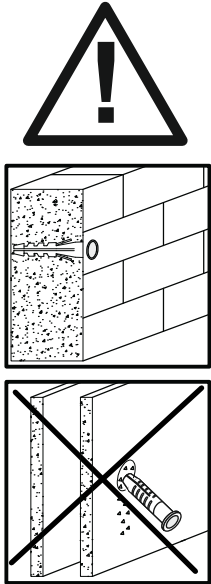
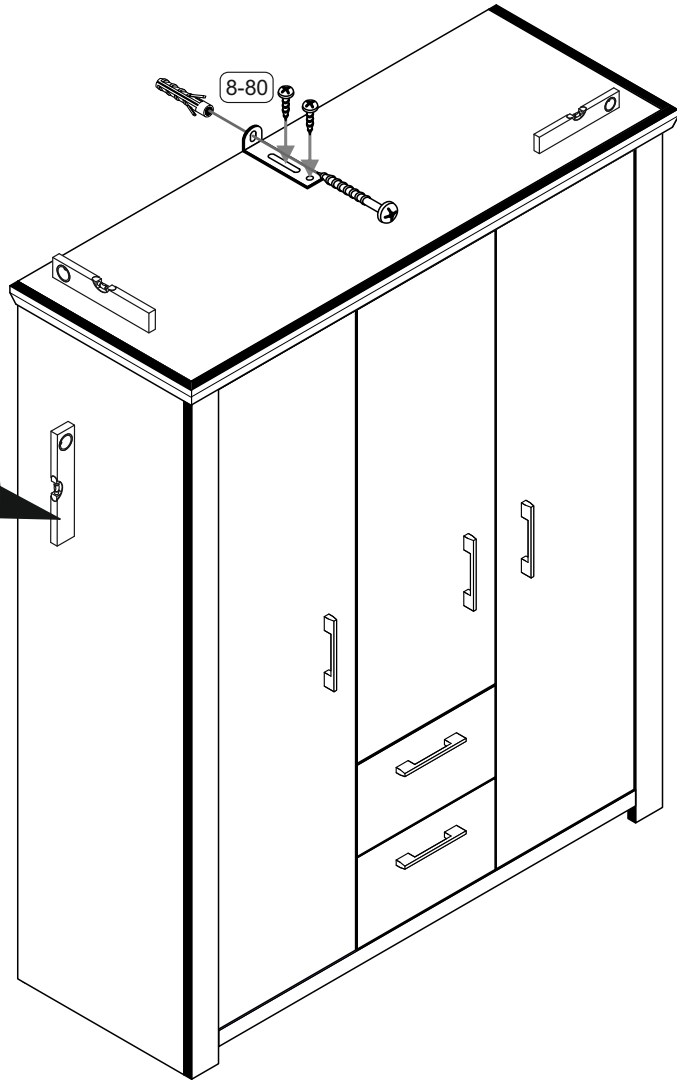
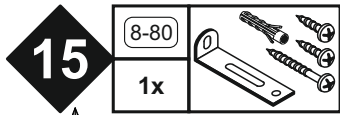

Achtung • Attention • Attenzione • Opgelet • Uwaga • Pozor • Figyelem • Atenție • Dikkat • Внимание	
(D)	Wandbefestigung dient als Kippschutz - unbedingt anbringen! Bei einigen Wandtypen kann ein Spezialdübel erforderlich sein!
(GB)	The wall fastening serves to prevent tipping - be absolutely sure to mount it! For certain wall types, a special wall plug may be necessary!
(FR)	La fixation murale sert de protection contre le basculement – à installer impérativement ! Pour certains types de murs il faut des chevilles spéciales !
(TR)	Duvardaki sabitleme, devrilmeye karşı bir emniyet tedbiridir ve mutlaka monte edilmelidir! Bazı duvar tiplerinde bunun için özel bir dübel gerekli olabilir!
(IT)	Il fissaggio alla parete serve da protezione anti-ribaltamento – attaccarla assolutamente! Per alcune strutture di parete può essere necessario un tassello speciale!
(NL)	Bevestiging aan de muur dient als kantelbescherming – zeker en vast bevestigen! Bij enkele muurtypes is een speciale plug misschien vereist!
(RU)	Обязательно установите крепление на стене во избежание опрокидывания! Для некоторых типов стен может потребоваться специальный дюбель!
(CZ)	Montáž na stěnu slouží jako ochrana proti převrnutí – bezpodmínečně umístěte! U některých typů stěn může být zapotřebí speciální hmoždinka!
(HU)	A terméket a falhoz kel rögzíteni, különben az felborulhat! Egyes faltípusoknál speciális tiplit kell használni!
(RO)	Sistemul de fixare la perete servește ca protecție la răsturnare - de montat obligatoriu! Pentru unele tipuri de pereți este posibil să fie necesar un diblu special!
(PL)	Mocowanie do ściany jest jednocześnie zabezpieczeniem przed przewróceniem – koniecznie zamontować! Do niektórych rodzajów ścian koniecznie zastosować specjalne kołki mocujące.
(SK)	Upevnenie na stenu slúži ako ochrana proti prevráteniu – bezpodmienečne použite! Pre niektoré druhy stien môže byť potrebná špeciálna hmoždinka!



(D) Montageanleitung

(GB) Assembly instructions

(FR) Notice de montage

(TR) Montaj talimatı

(IT) Istruzioni di montaggio

(NL) Handleiding voor de montage

(RU) Инструкция по монтажу

(CZ) Montážní návod

(HU) Szerelési útmutató

(RO) Instrucțiuni de montaj

(PL) Instrukcja montażu

(SK) Návod na montáž

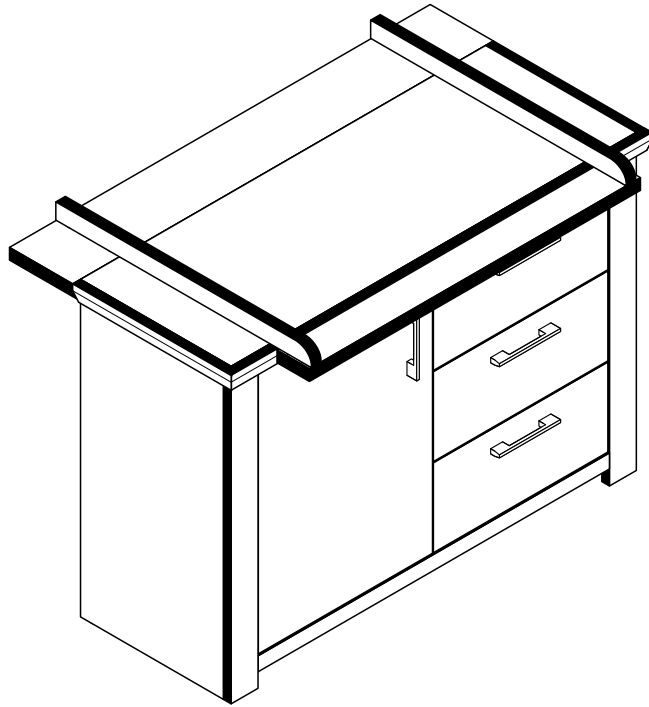

0442-Wiko_13 Wickelkommode

Service • Assistenza • Dienstverlening • Servis
Servis • Szerviz • Сервисная служба

			<p>Colli 1/2 : (5) (8) (11) (15) (16) (17) (18) (19) (20) (21) (22) (23) (24) Beutel 1/3, 2/3, 3/3</p> <p>Colli 2/2 : (1) (2) (3) (4) (6) (7) (9) (10) (12) (13) (14) (25) (26) (27)</p>

Beutel 1/3

1-10 12x		6,3x50	1-30 24x		3x16	1-37 1x		4,5x25	1-70 6x		3x30	1-80 12x		3,5x13	1-90 4x		3,5x20
1-200 12x		6,3x13	1-329 8x		M4x22	2-08 12x		h=10mm	2-10 29x		h=12mm	2-20 41x		2-160 4x			
2-220 2x			8-80 1x														

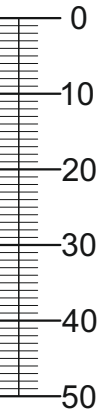

Beutel 2/3

3-07 1x		3-63 2x		3-64 2x	
------------	--	------------	--	------------	--

Beutel 3/3

3-130 8x		5-185 4x		5-190 2x		6-415 4x	
-------------	--	-------------	--	-------------	--	-------------	--

Colli 1/2

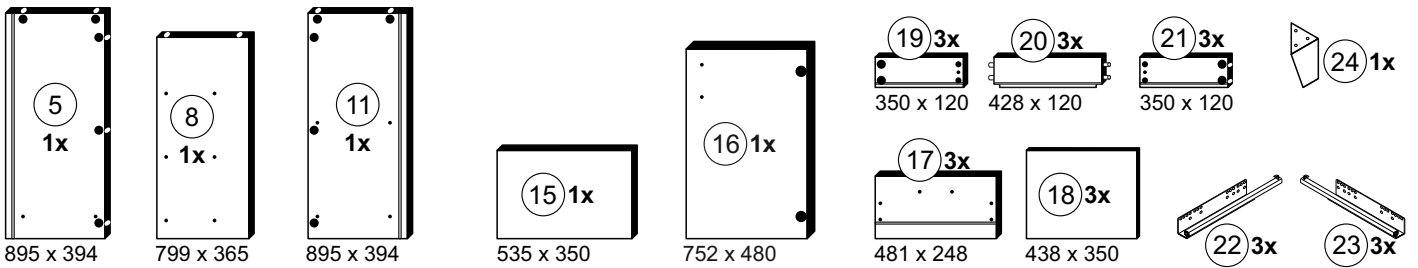

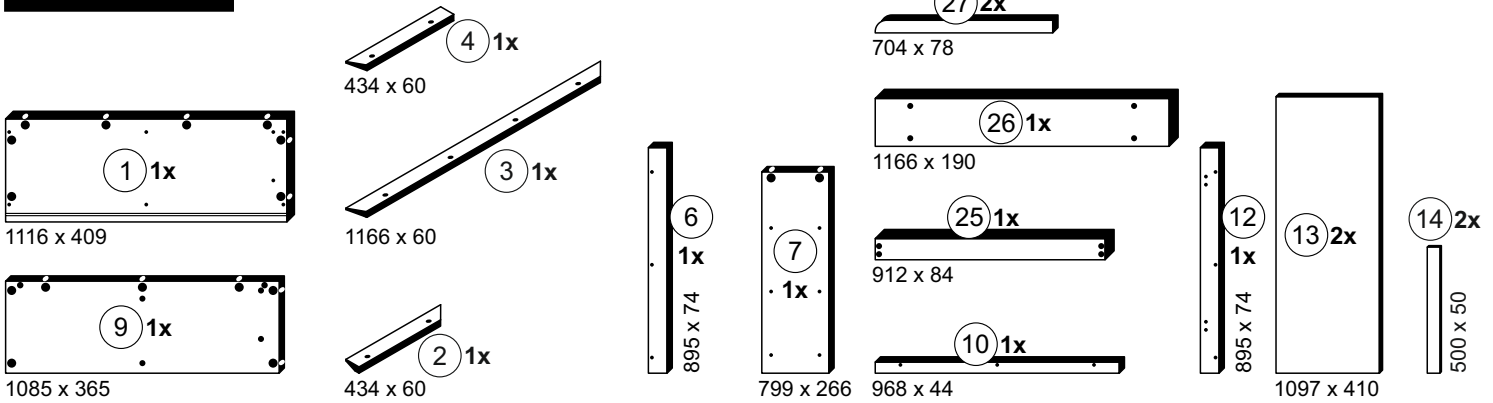

Colli 2/2

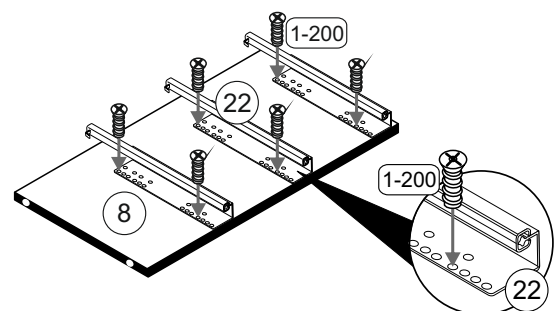
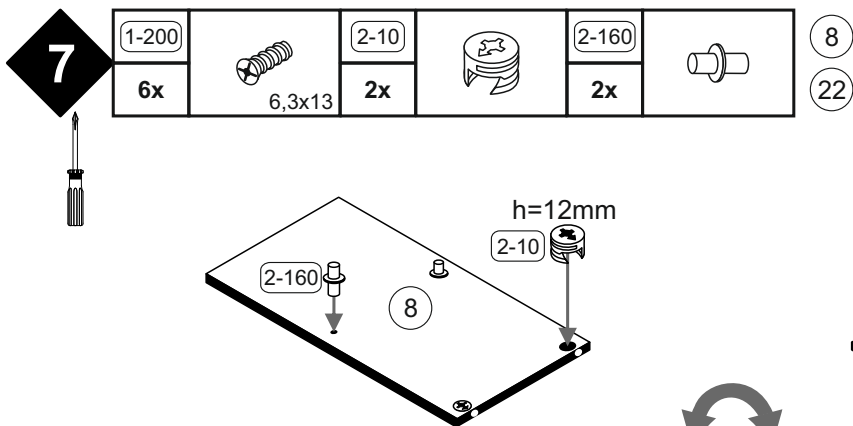
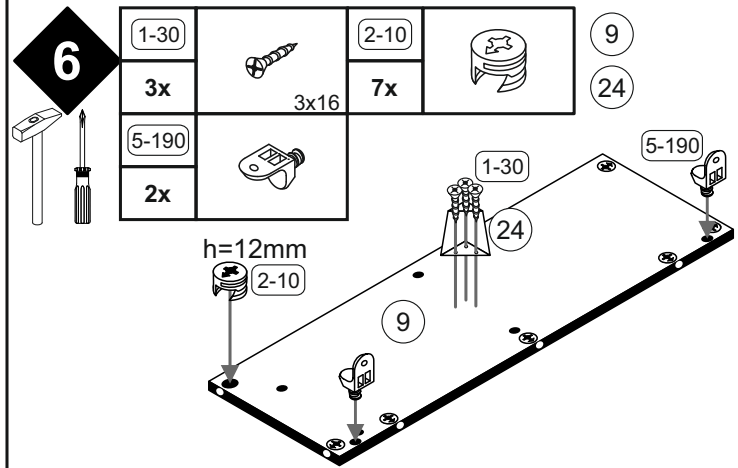
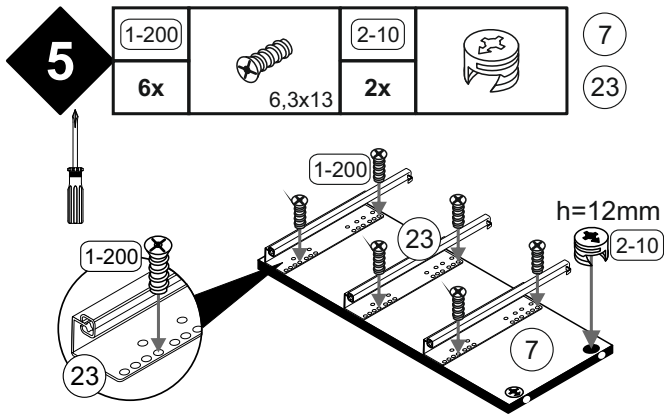
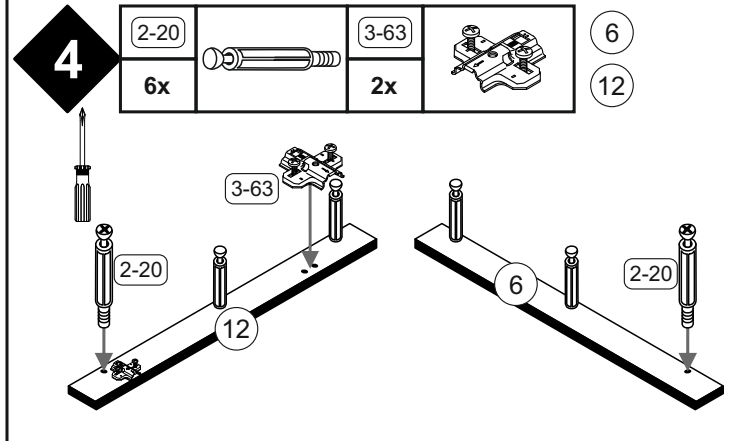
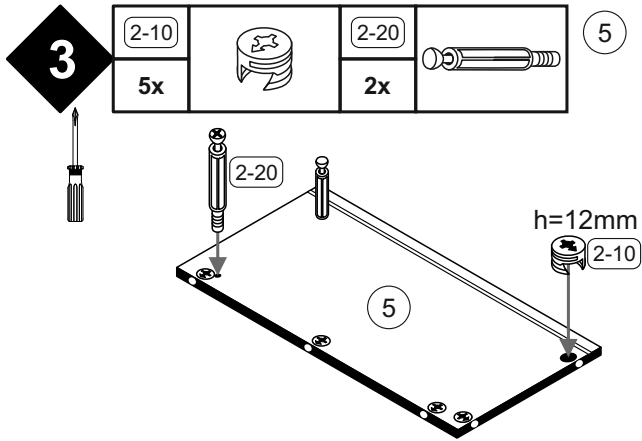
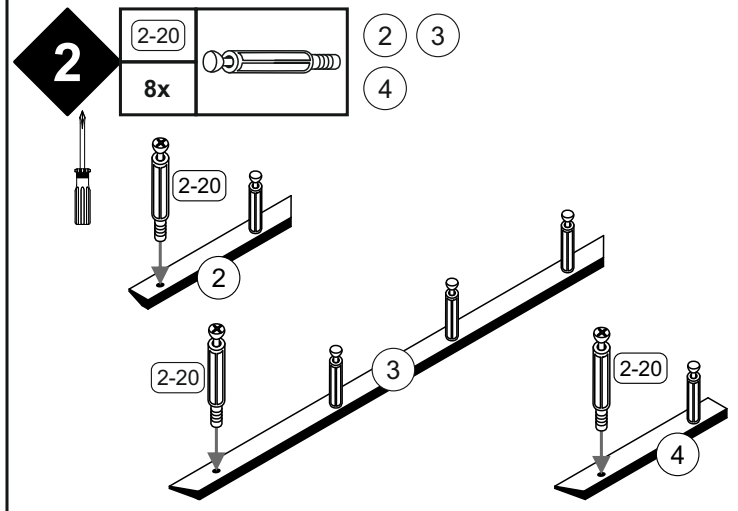
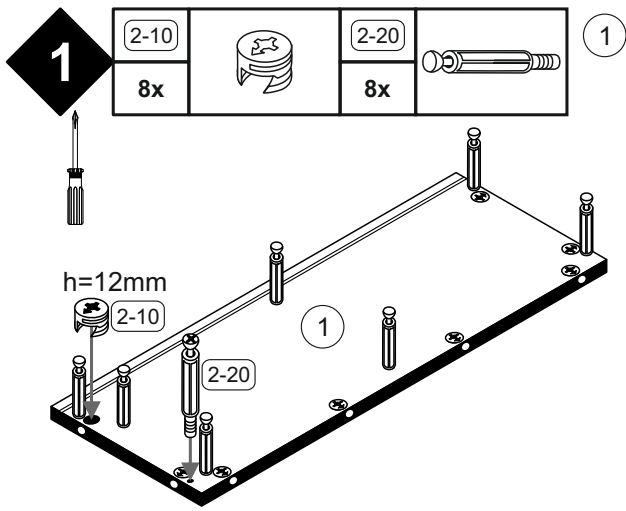

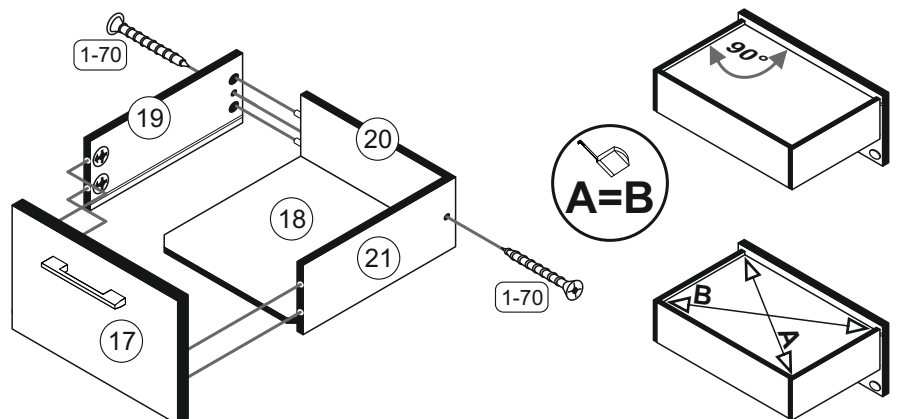
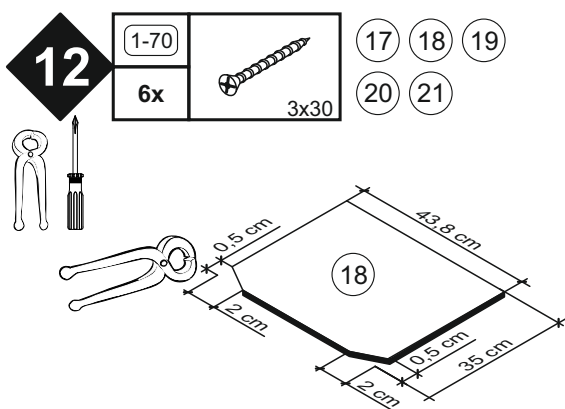
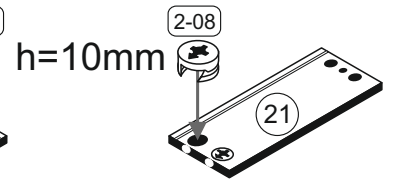
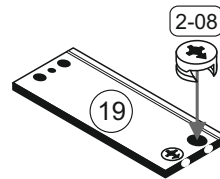
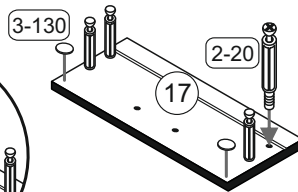
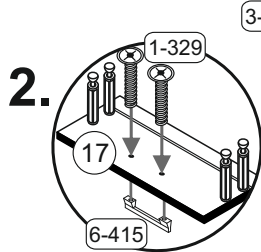
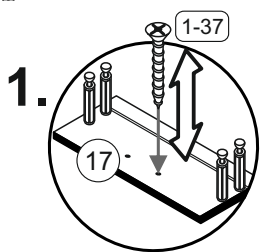
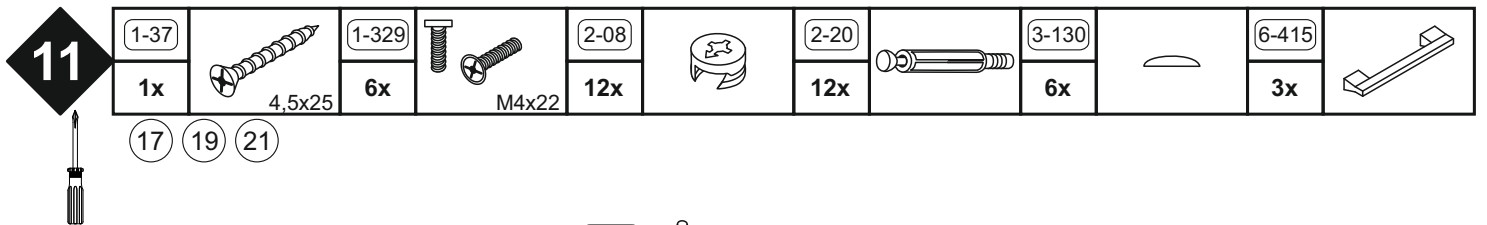
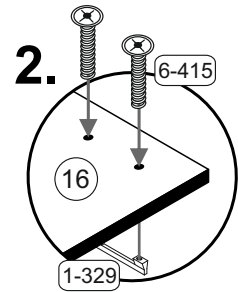
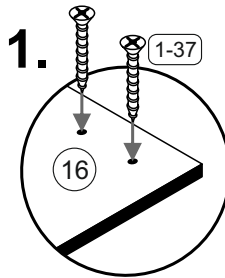
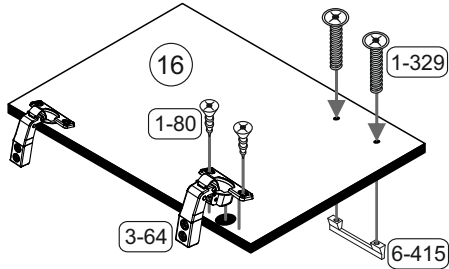
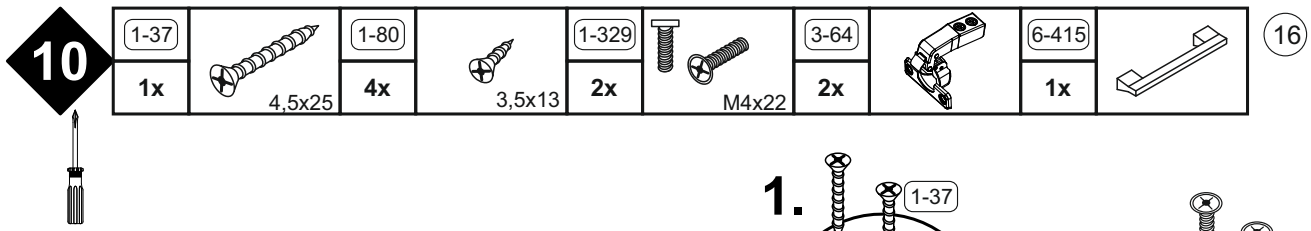
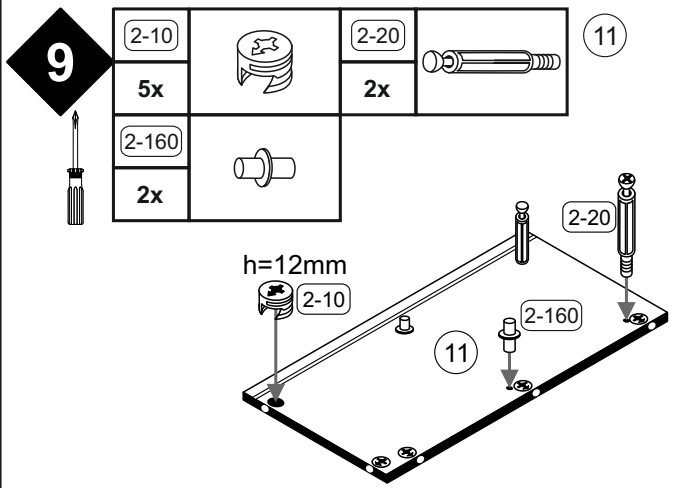
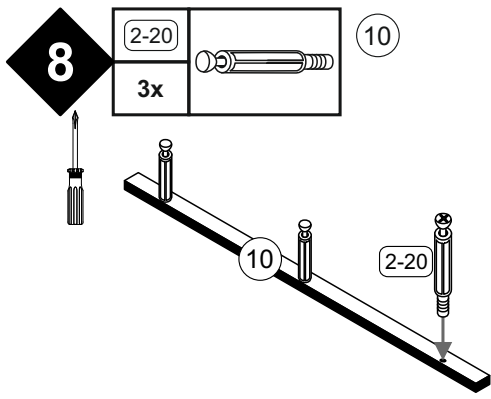





13

1-80		3,5x13
4x		
2-220		
2x		

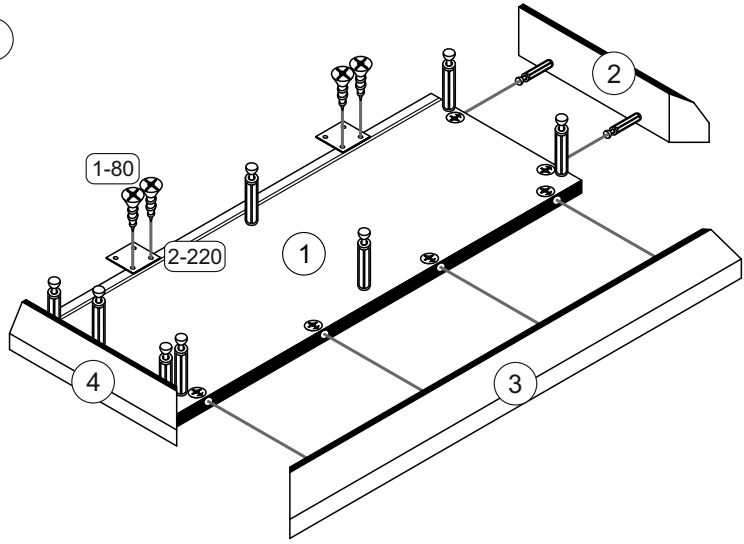





14

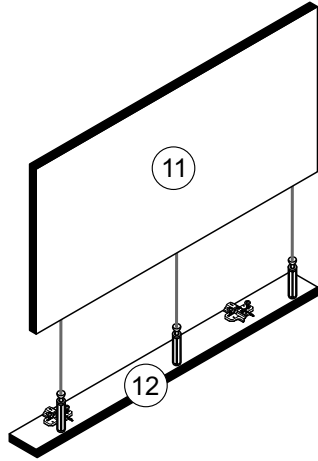
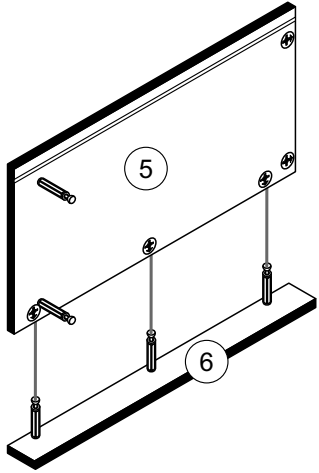

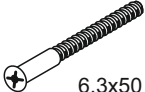

15

1-10		6,3x50
4x		



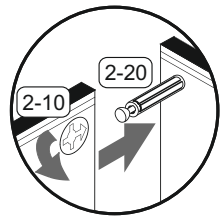
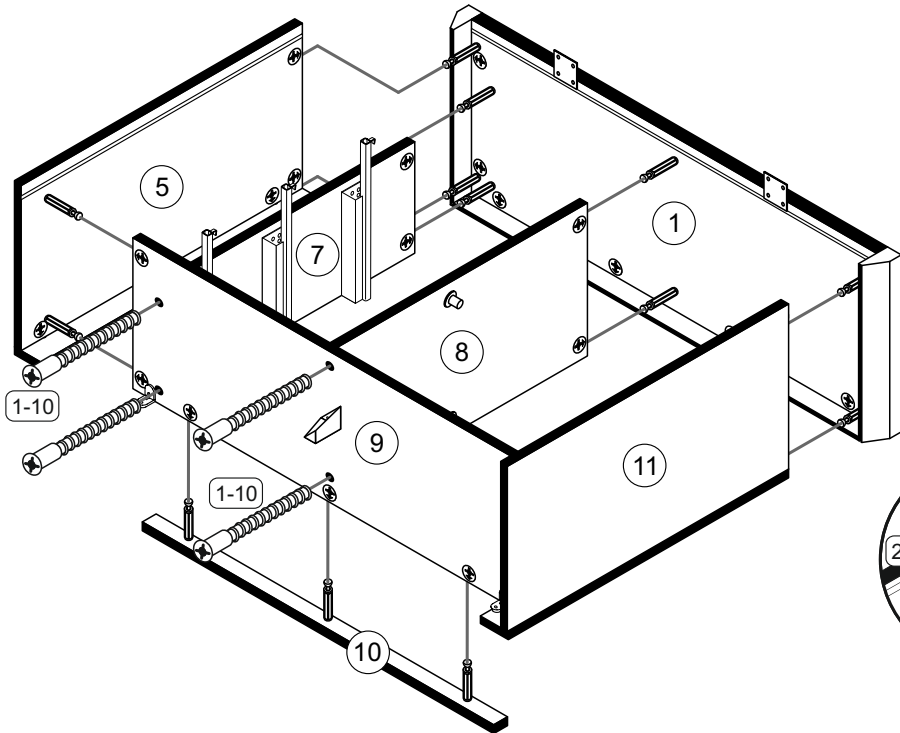

16

1-30		1-90		5-185	
21x	3x16	4x	3.5x20	4x	

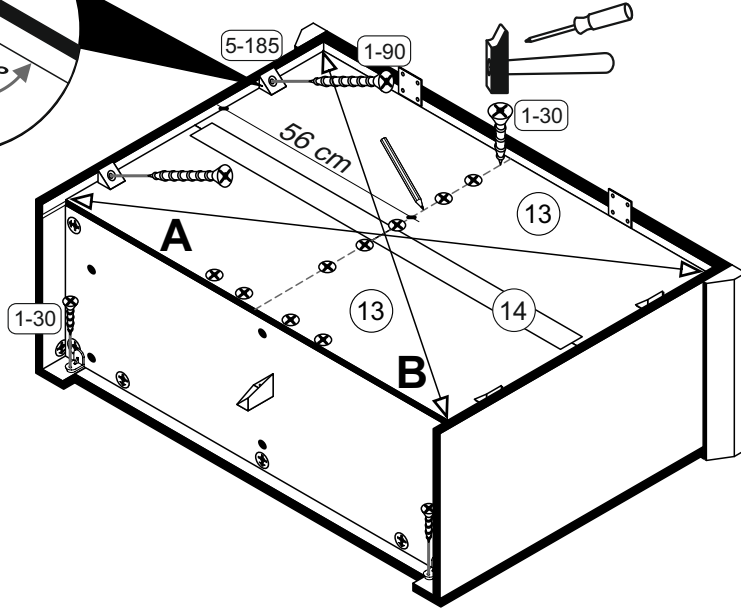
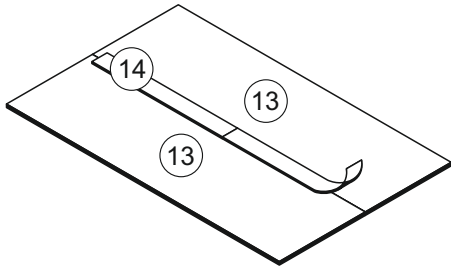
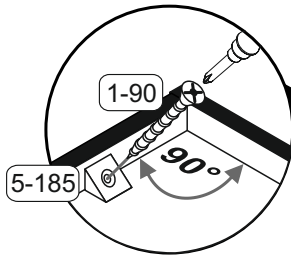
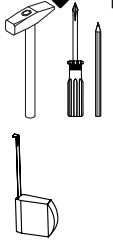

17

1-10		8-80		25	26
8x	6,3x50	1x		27	

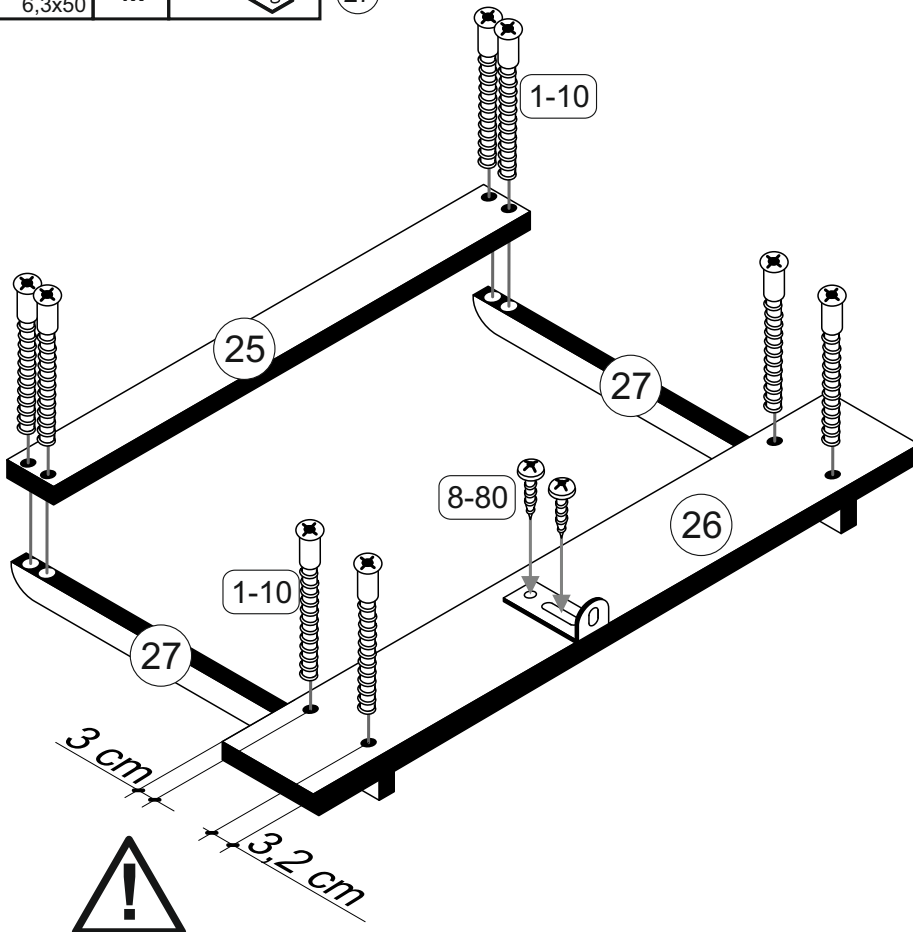

18

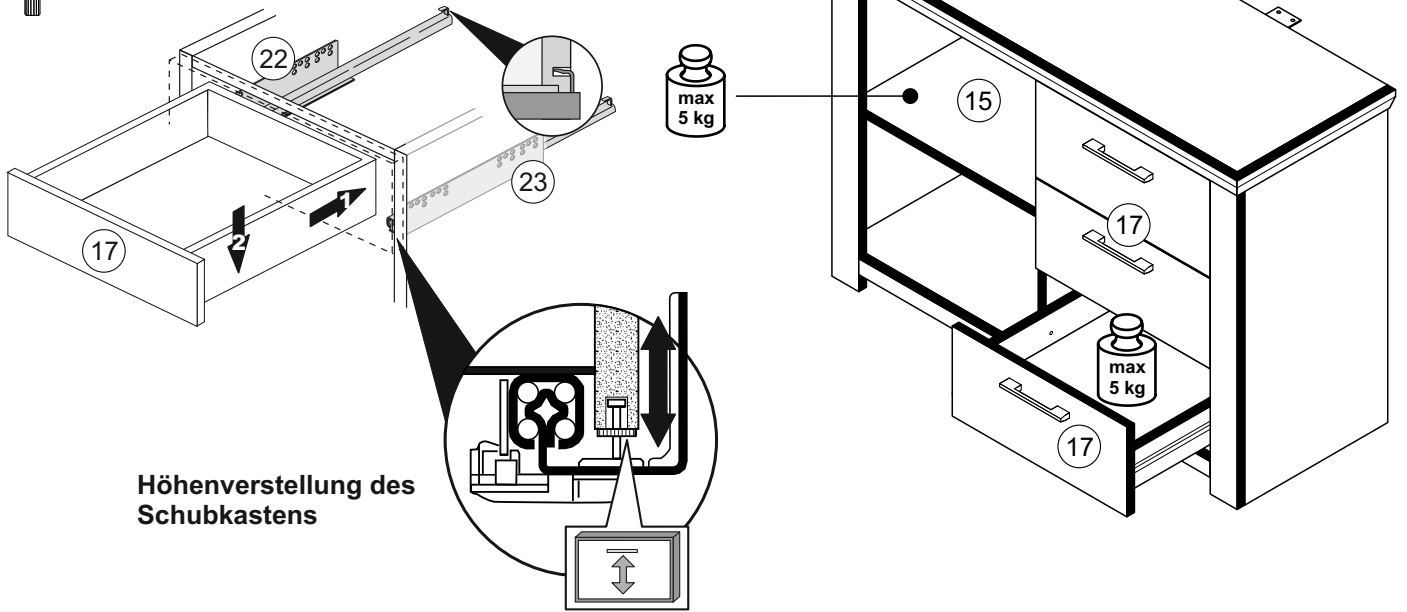

Höhenverstellung des Schubkastens

19



3-07		3-130	
1x		2x	

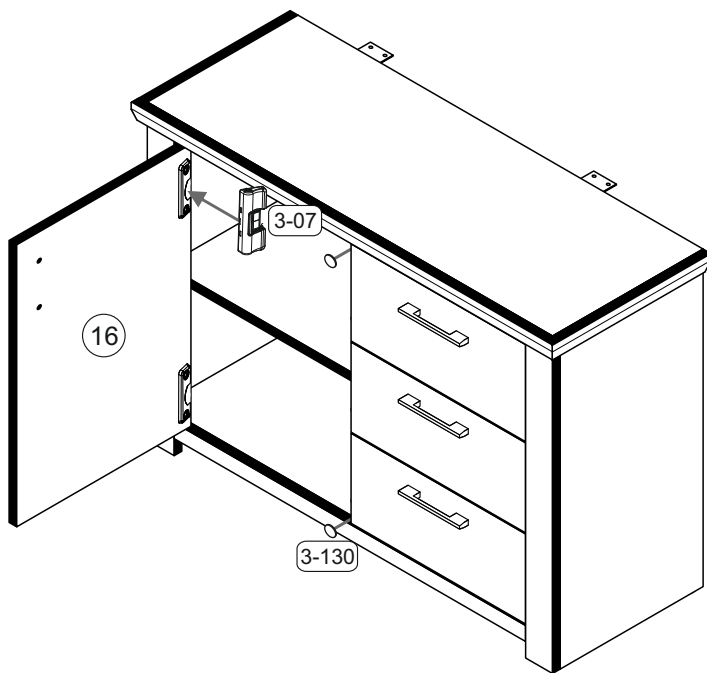

Montage der Tüрдämpfung

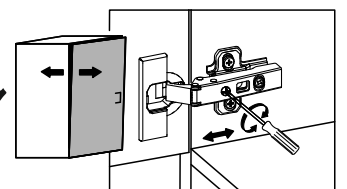
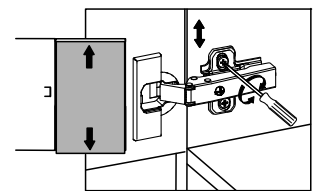
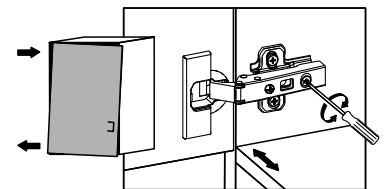
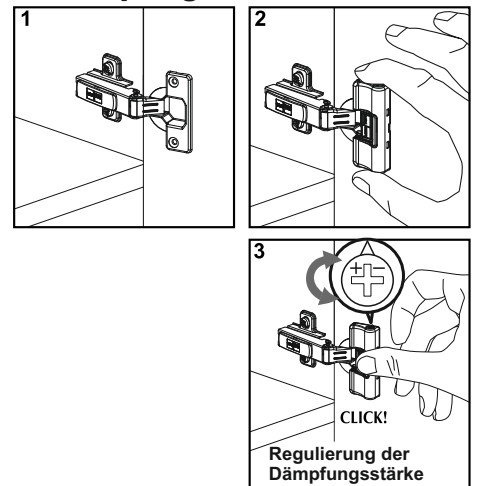

Türen einstellen (Scharniere justieren)

Adjusting the doors (adjusting the hinges)

Régler les portes (ajuster les charnières)

Sistemare le porte (regolare le cerniere)

Deuren instellen (scharnieren afstellen)

Nastawić drzwi (wyregulować zawiasy)

Vyrovnejte dvířka (seřid'te závěsy)

Nastavenie dverí (nastavenie závesov)

Állítsa be az ajtókat (állítsa be a zsanérokot)

Reglare uși (ajustare balamale)

Kapıların ayarlanması (menteşelerin seviye ayarı)

Регулировка дверей (регулировка шарнира)

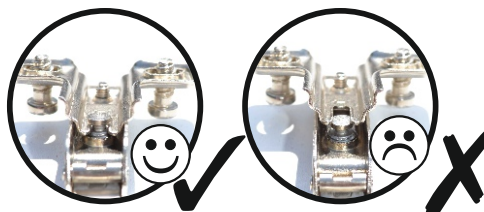

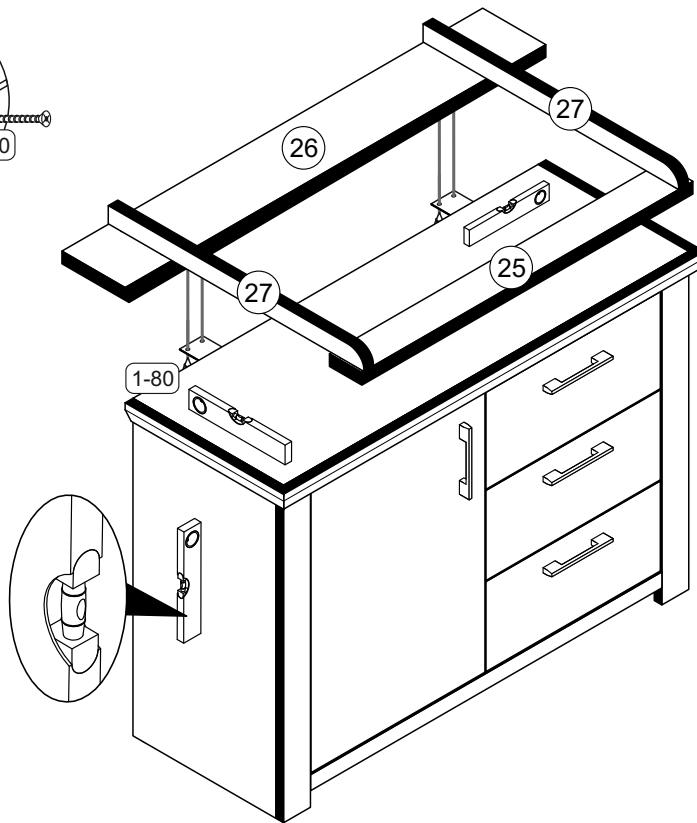
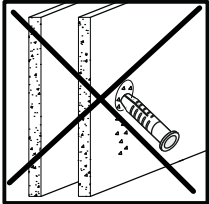
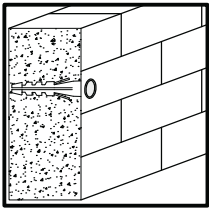
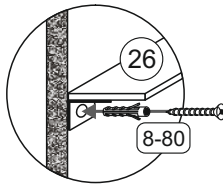
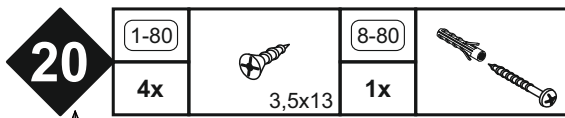

Achtung • Attention • Attenzione • Opgelet • Uwaga • Pozor • Figyelem • Atenție • Dikkat • Внимание	
(D)	Wandbefestigung dient als Kippschutz - unbedingt anbringen! Bei einigen Wandtypen kann ein Spezialdübel erforderlich sein!
(GB)	The wall fastening serves to prevent tipping - be absolutely sure to mount it! For certain wall types, a special wall plug may be necessary!
(FR)	La fixation murale sert de protection contre le basculement – à installer impérativement ! Pour certains types de murs il faut des chevilles spéciales !
(TR)	Duvardaki sabitleme, devrilmeye karşı bir emniyet tedbiridir ve mutlaka monte edilmelidir! Baz duvar tiplerinde bunun için özel bir dübel gerekli olabilir!
(IT)	Il fissaggio alla parete serve da protezione anti-ribaltamento – attaccarla assolutamente! Per alcune strutture di parete può essere necessario un tassello speciale!
(NL)	Bevestiging aan de muur dient als kantelbescherming – zeker en vast bevestigen! Bij enkele muurtypes is een speciale plug misschien vereist!
(RU)	Обязательно установите крепление на стене во избежание опрокидывания! Для некоторых типов стен может потребоваться специальный дюбель!
(CZ)	Montáž na stěnu slouží jako ochrana proti převrnutí – bezpodmínečně umístěte! U některých typů stěn může být zapotřebí speciální hmoždinka!
(HU)	A terméket a falhoz kel rögzíteni, különben az felborulhat! Egyes faltípusoknál speciális tiplít kell használni!
(RO)	Sistemul de fixare la perete servește ca protecție la răsturnare - de montat obligatoriu! Pentru unele tipuri de pereți este posibil să fie necesar un diblu special!
(PL)	Mocowanie do ściany jest jednocześnie zabezpieczeniem przed przewróceniem – koniecznie zamontować! Do niektórych rodzajów ścian koniecznie zastosować specjalne kołki mocujące.
(SK)	Upevnenie na stenu slúži ako ochrana proti prevráteniu – bezpodmienečne použite! Pre niektoré druhy stien môže byť potrebná špeciálna hmoždinka!